



U74HCT4066

CMOS IC

QUAD BILATERAL SWITCH

DESCRIPTION

The UTC **U74HCT4066** consists of four independent analog switches. Each switch has an Enable input (nE) which is active HIGH to decide the switch status.

FEATURES

- *Operation voltage range: 4.5V~5.5V
- *Very low "ON" resistance: 50Ω(Typ.)@V_{CC}=4.5V

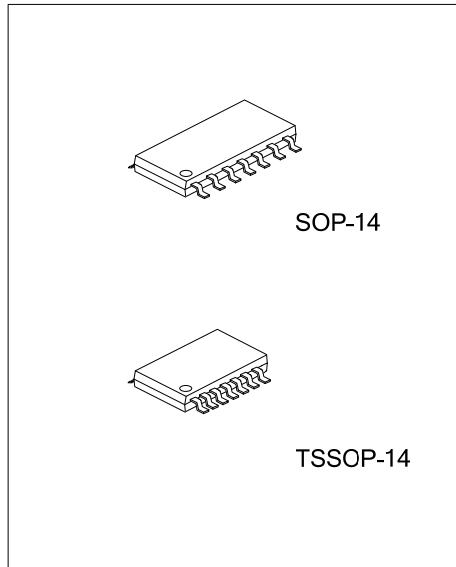

ORDERING INFORMATION

Ordering Number		Package	Packing
Lead Free	Halogen Free		
U74HCT4066L-P14-R	U74HCT4066G-P14-R	SOP-14	Tape Reel
U74HCT4066L-S14-R	U74HCT4066G-S14-R	TSSOP-14	Tape Reel

U74HCT4066G-S14-R	(1) Packing Type	(1) R: Tape Reel
	(2) Package Type	(2) S14: SOP-14, P14: TSSOP-14
	(3) Green Package	(3) G: Halogen Free and Lead Free, L: Lead Free

MARKING

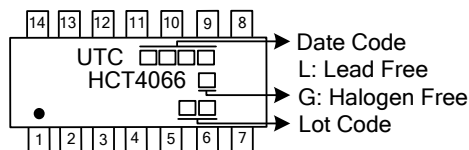

■ PIN CONFIGURATION

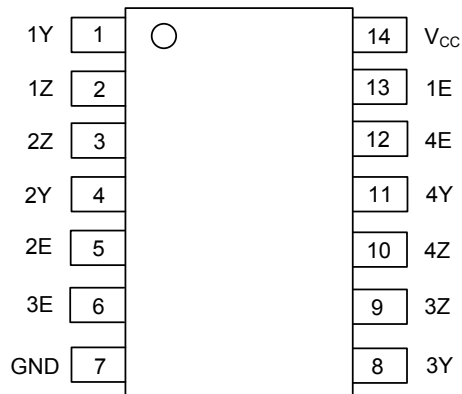

■ FUNCTION TABLE

INPUTS(nE)	SWITCH
H	ON
L	OFF

Note: H: High voltage level; L: Low voltage level.

■ LOGIC DIAGRAM

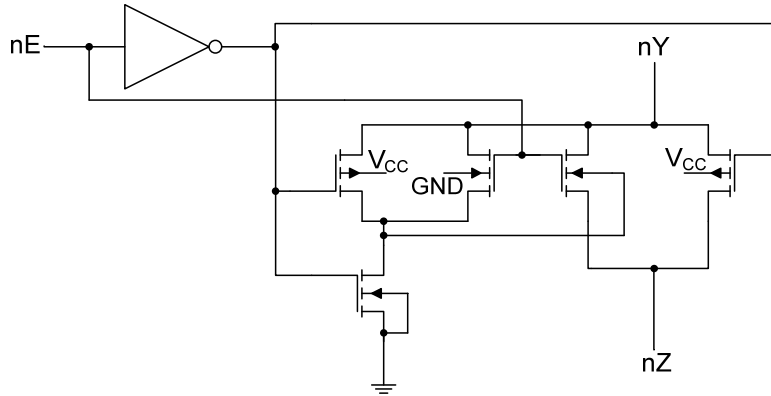

■ ABSOLUTE MAXIMUM RATING (T_A=25°C, unless otherwise specified)

PARAMETER		SYMBOL	RATINGS	UNIT
Supply Voltage		V _{CC}	-0.5 ~ +11	V
Input Diode Current		I _{IK}	±20	mA
Switch Diode Current		I _{SK}	±20	mA
Switch Current		I _S	±25	mA
VCC or GND Current		I _{CC}	±50	mA
Power Dissipation		P _D	500	mW
Derate above 60°C	TSSOP-14		5.5	mW/°C
Derate above 70°C	SOP-14		8	mW/°C
Storage Temperature		T _{STG}	-65 ~ +150	°C

Note: Absolute maximum ratings are those values beyond which the device could be permanently damaged. Absolute maximum ratings are stress ratings only and functional device operation is not implied.

■ RECOMMENDED OPERATING CONDITIONS (T_A=25°C, unless otherwise specified)

PARAMETER	SYMBOL	TEST CONDITIONS	MIN	TYP	MAX	UNIT
Supply Voltage	V _{CC}		4.5	5.0	5.5	V
Input Voltage	V _{IN}		GND		V _{CC}	V
Switch Voltage	V _S		GND		V _{CC}	V
Input Transition Rise or Fall Rate	t _R , t _F	V _{CC} =2V		6	500	ns
Operating Temperature	T _A		-40		85	°C

■ ELECTRICAL CHARACTERISTICS (T_A=25°C, unless otherwise specified)

PARAMETER	SYMBOL	TEST CONDITIONS	MIN	TYP	MAX	UNIT
High-Level Input Voltage	V _{IH}	V _{CC} =4.5V to 5.5V	2			V
Low-Level Input Voltage	V _{IL}	V _{CC} =4.5V to 5.5V			0.8	V
Input Leakage Current	I _{I(LEAK)}	V _{CC} =5.5V, V _{IN} =V _{CC} or GND			±1.0	μA
current per channel	I _S	V _{CC} =5.5V, V _{IN} =V _{IH} or V _{IL} , V _S =V _{CC} -GND			±1.0	μA
OFF-state						±1.0
ON-state					±1.0	μA
Quiescent Supply Current	I _Q	V _{CC} =4.5V to 5.5V, V _{IN} =V _{IS} =V _{OS} =V _{CC} or GND			20	μA
Additional Quiescent Supply Current	Δ I _Q	V _{CC} =4.5V to 5.5V, V _{IN} =V _{CC} -2.1V, Other inputs at V _{CC} or GND		100	450	μA
ON-resistance	Peak	R _{ON}	V _{IN} =V _{IH} or V _{IL} , V _{IS} =V _{CC} to GND, V _{CC} =4.5V, I _S =1mA	54	118	Ω
	Rail	R _{ON}	V _{IN} =V _{IH} or V _{IL} , V _{IS} =GND, V _{CC} =4.5V, I _S =1mA	35	95	Ω
Maximum variation of ON-resistance between any two channels	Δ R _{ON}	V _{IN} =V _{IH} or V _{IL} , V _{IS} =V _{CC} to GND, V _{CC} =4.5V		5		Ω

■ DYNAMIC CHARACTERISTICS (T_A=25°C, GND=0V; t_R=t_F=6ns; C_L=50pF)

PARAMETER	SYMBOL	TEST CONDITIONS	MIN	TYP	MAX	UNIT
Propagation Delay From V _{IS} to V _{OS}	t _{PHL} /t _{PLH}	V _{CC} =4.5V, R _L =∞		3	15	ns
Turn-ON Time from nE to V _{OS}	t _{PZH} /t _{PZL}	V _{CC} =4.5V, R _L =1KΩ		12	30	ns
Turn-OFF Time from nE to V _{OS}	t _{PHZ} /t _{PLZ}	V _{CC} =4.5V, R _L =1KΩ		20	44	ns
Sine-Wave Distortion	THD	V _{CC} =4.5V, V _{IS(P-P)} =4V, f=1kHz, R _L =10k		0.04		%
Switch OFF Signal Feed-Through (Note 1)	α _{OFF}	V _{CC} =4.5V, R _L =600Ω, f=1MHz		-50		dB
Crosstalk Between any two Switches (Note 1)	α _{CT(S)}	V _{CC} =4.5V, R _L =600Ω, f=1MHz		-60		dB
Crosstalk Voltage between any input to any Switch (Peak-to-Peak Value)	V _(P-P)	V _{CC} =4.5V, R _L =600Ω, f=1MHz		110		mV

■ DYNAMIC CHARACTERISTICS(Cont.)

PARAMETER	SYMBOL	TEST CONDITIONS	MIN	TYP	MAX	UNIT
Minimum Frequency Response(-3dB) (Note 2)	f_{MAX}	$V_{CC}=4.5V, R_L=50\Omega, C_L=10pF$		180		MHz
maximum switch capacitance	C_S			8		pF

Notes: 1. Adjust input voltage V_{IS} is 0dbm level (0dbm=1mW into 600 Ω)

2. Adjust input voltage V_{IS} is 0dbm level at V_{OS} for 1MHz (0dbm=1mW into 50 Ω)

■ TEST CIRCUIT AND WAVEFORMS

Test circuit for measuring ON-resistance (Ron)

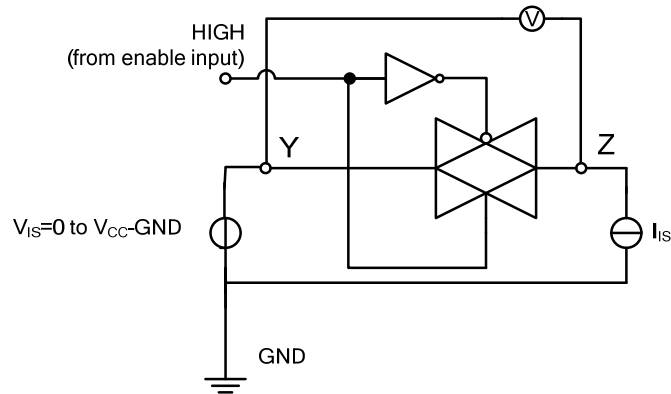

Test circuit for measuring OFF-state current

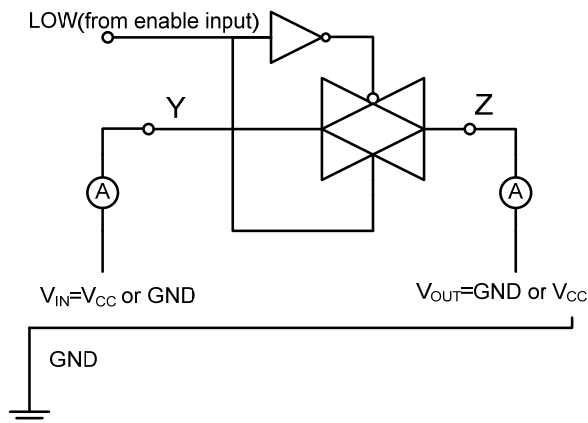

Test circuit for measuring ON-state current

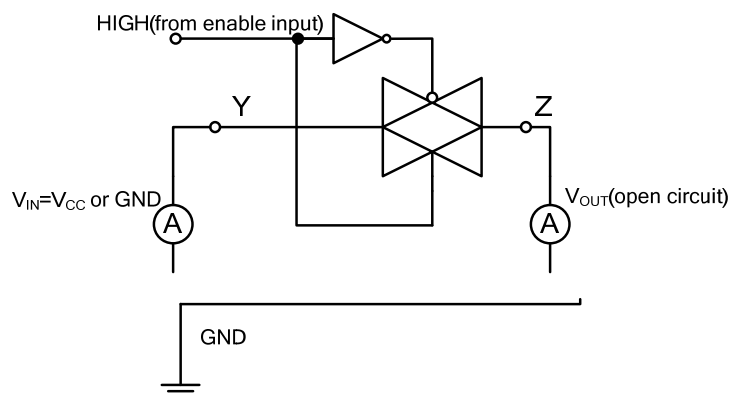

■ TEST CIRCUIT AND WAVEFORMS(Cont.)

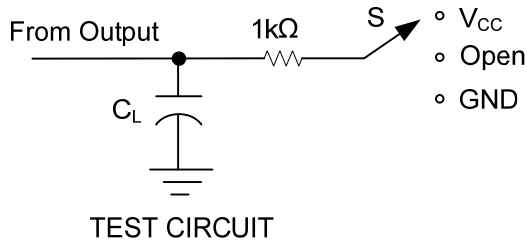

	S	V _{IN}
t _{PLH} /t _{PHL}	OPEN	
t _{PHZ} /t _{PZH}	GND	V _{CC}
t _{PLZ} /t _{PZL}	V _{CC}	GND

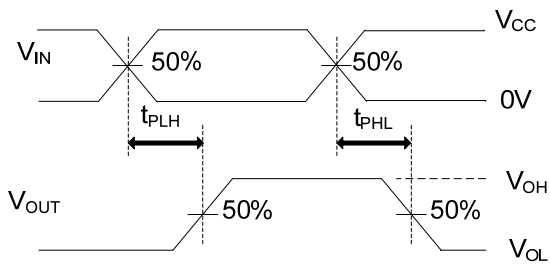

PROPAGATION DELAY TIMES

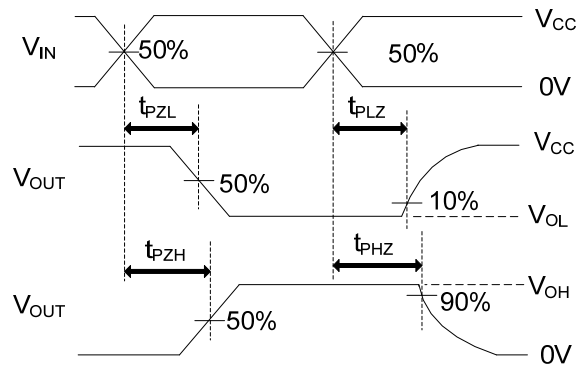

ENABLE AND DISABLE TIMES

Note: 1. C_L includes probe and jig capacitance.
 Note: 2. PRR ≤ 1MHz, Z_o = 50Ω, t_R ≤ 6ns, t_F ≤ 6ns.

UTC assumes no responsibility for equipment failures that result from using products at values that exceed, even momentarily, rated values (such as maximum ratings, operating condition ranges, or other parameters) listed in products specifications of any and all UTC products described or contained herein. UTC products are not designed for use in life support appliances, devices or systems where malfunction of these products can be reasonably expected to result in personal injury. Reproduction in whole or in part is prohibited without the prior written consent of the copyright owner. The information presented in this document does not form part of any quotation or contract, is believed to be accurate and reliable and may be changed without notice.