



## UA9849

## LINEAR INTEGRATED CIRCUIT

### 3-PHASE MOTOR DRIVER FOR CD-ROMS

#### DESCRIPTION

The UTC **UA9849** is ICs developed for CD-ROM spindle motor drives. These ICs possess a short brake and reverserotation brake for two types of brake functions, and also contain FG output and rotation direction detection (FR) circuits, making them high-functionality and high-performance ICs.

#### FEATURES

- \* Three-phase, full-wave, pseudo-linear drive system.
- \* Built-in power save and thermal shutdown functions.
- \* Built-in current limiter and Hall bias circuits.
- \* Built-in FG output.
- \* Built-in rotation direction detector.
- \* Built-in reverse rotation prevention circuit.
- \* Built-in short brake pin.

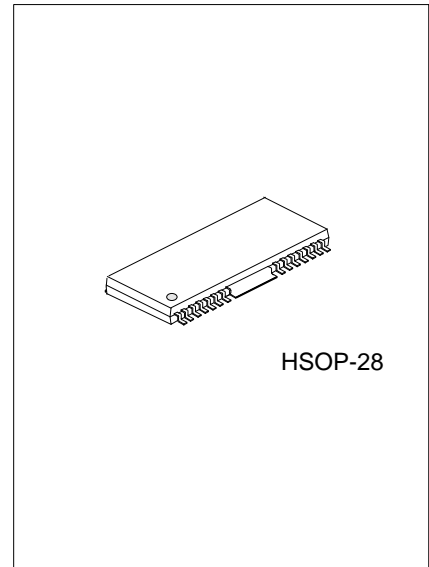

HSOP-28

Lead-free: UA9849L  
Halogen-free: UA9849G

#### ORDERING INFORMATION

Ordering Number			Package	Packing
Normal	Lead Free	Halogen Free		
UA9849-SH1-T	UA9849L-SH1-T	UA9849G-SH1-T	HSOP-28	Tube

<p>UA9849L-SH1-T</p> <p>(1)Packing Type</p> <p>(2)Package Type</p> <p>(3)Lead Plating</p>	<p>(1) T: Tube</p> <p>(2) SH1: HSOP-28</p> <p>(3) G: Halogen Free, L: Lead Free, Blank: Pb/Sn</p>
---	---

■ PIN DESCRIPTION

PIN #	PIN NAME	FUNCTOIN
2	A3	Output
4	A2	Output
7	A1	Output
8	GND	GND
9	H1 <sup>+</sup>	Hall Signal Input
10	H1 <sup>-</sup>	Hall Signal Input
11	H2 <sup>+</sup>	Hall Signal Input
12	H2 <sup>-</sup>	Hall Signal Input
13	H3 <sup>+</sup>	Hall Signal Input
14	H3 <sup>-</sup>	Hall Signal Input
15	V <sub>H</sub>	Hall Bias
17	C <sub>NF</sub>	For connection of phase compensation capacitor
18	SB	Short brake
20	FR	Rotation direction detection
21	E <sub>CR</sub>	Output voltage control reference
22	E <sub>C</sub>	Output voltage control
23	PS	Power save
24	FG	FG signal output
25	V <sub>CC</sub>	Power Supply
26	V <sub>M2</sub>	Motor Power Supply 2
27	V <sub>M1</sub>	Motor Power Supply 1
28	R <sub>NF</sub>	For connection of output current detection resistor
FIN	-	SUB GND

■ BLOCK DIAGRAM

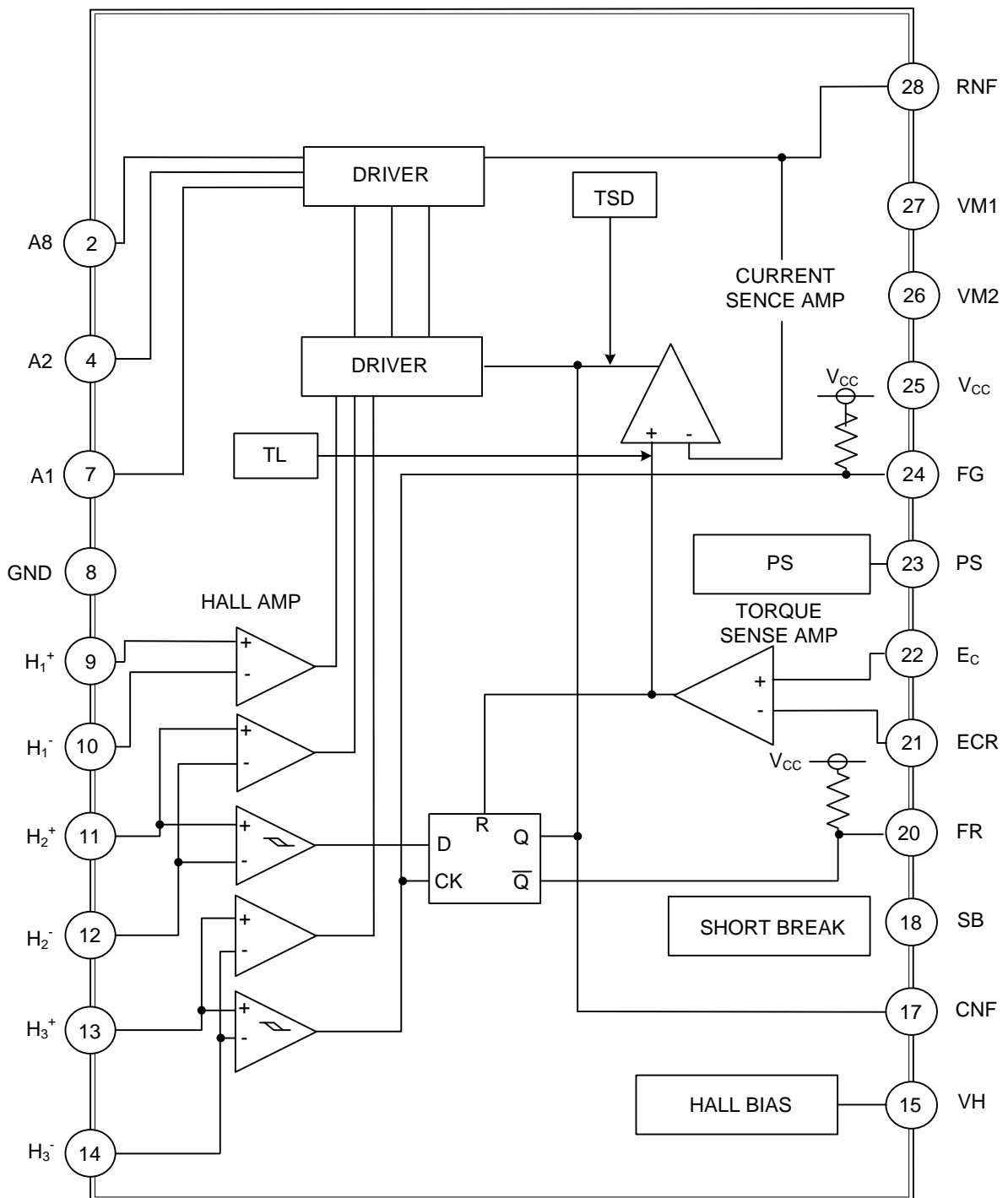

## ■ ABSOLUTE MAXIMUM RATINGS

PARAMETER	SYMBOL	RATINGS	UNIT
Applied Voltage ( with 5V Power Supply)	V <sub>CC</sub>	7	V
Applied Voltage ( motor Power Supply1 )	V <sub>M1</sub>	16	V
Applied Voltage ( motor Power Supply2)	V <sub>M2</sub>	16	V
Output Current(Note 4)	I <sub>OUT</sub>	1.3	A
Power Dissipation(Note 2)	P <sub>D</sub>	2.2	W
Operating Temperature	T <sub>OPR</sub>	-20 ~ 75	°C
Storage Temperature(Note 3)	T <sub>STG</sub>	-55 ~ 150	°C

Note: 1. Absolute maximum ratings are those values beyond which the device could be permanently damaged.

Absolute maximum ratings are stress ratings only and functional device operation is not implied.

2. Reduced by 17.6mW for increase for T<sub>A</sub> of 1°C over 25°C

3. T<sub>J</sub> should not exceed 150°C

4. T<sub>J</sub> should not exceed P<sub>D</sub> or ASO value.

## ■ RECOMMENDED OPERATING CONDITIONS (T<sub>A</sub> =25°C)

PARAMETER	SYMBOL	MIN	TYP	MAX	UNIT
Power Supply Voltage	V <sub>CC</sub>	4.25		5.5	V
	V <sub>M1</sub>	3.0		15	
	V <sub>M2</sub>	3.0		15	

## ■ ELECTRICAL CHARACTERISTICS

(T<sub>A</sub>=25°C, V<sub>CC</sub>=5V, V<sub>M1</sub>=12V, V<sub>M2</sub>=12V, unless otherwise specified.)

PARAMETER	SYMBOL	TEST CONDITIONS	MIN	TYP.	MAX	UNIT
<b>Total Device</b>						
Circuit Current 1	I <sub>CC1</sub>	In the power save ON state		0	0.2	mA
Circuit Current 2	I <sub>CC2</sub>	In the power save OFF state		4.1	6.5	mA
<b>Power Save</b>						
ON Voltage Range	V <sub>PSON</sub>				1.5	V
OFF Voltage Range	V <sub>PSOFF</sub>		3.5			V
<b>Hall Bias</b>						
Hall Bias Voltage	V <sub>HB</sub>	I <sub>HB</sub> =10mA	0.5	0.9	1.5	V
<b>Hall Amplifier</b>						
Input Bias Current	I <sub>HA</sub>			0.7	3.0	μA
Same Phase Input Voltage Range	V <sub>HAR</sub>		1.5		4.0	V
Minimum Input Level	V <sub>INH</sub>		50			mV <sub>P-P</sub>
H3 Hysteresis Level	V <sub>HYS</sub>		10	20	40	mV
<b>Torque Command</b>						
Input Voltage Range	E <sub>C</sub>		1.0		4.0	V
"-"Offset Voltage	E <sub>COFF-</sub>	E <sub>CR</sub> =2.5V	-80	-50	-20	mV
"+"Offset Voltage	E <sub>COFF+</sub>	E <sub>CR</sub> =2.5V	20	50	80	mV
Input Bias Current	E <sub>CIN</sub>	E <sub>CR</sub> = EC		0.5	2.0	μA
I/O Gain	G <sub>EC</sub>	E <sub>C</sub> =1.5V,2.0V	0.41	0.51	0.61	A/V
<b>FG</b>						
FG Output High Level Voltage	V <sub>FGH</sub>	I <sub>FG</sub> = -20μA	4.5	4.8		V
FG Output Low Level Voltage	V <sub>FGL</sub>	I <sub>FG</sub> =3mA	0	0.25	0.4	V
Duty (Reference Value)	DU			50		%
<b>Rotation Detection</b>						
FR Output High Level Voltage	V <sub>FRH</sub>	V <sub>FRH</sub> = -20μA	4.1	4.4		V
FR Output Low Level Voltage	V <sub>FRL</sub>	I <sub>FR</sub> = 3A	0	0.25	0.4	V

■ ELECTRICAL CHARACTERISTICS(Cont.)

PARAMETER	SYMBOL	TEST CONDITIONS	MIN	TYP.	MAX	UNIT
<b>Output</b>						
Output Saturation High Level Voltage	$V_{OH}$	$I_O = -600\text{mA}$		1.0	1.5	V
Output Saturation Low Level Voltage	$V_{OL}$	$I_O = 600\text{mA}$		0.4	0.8	V
Pre-Drive Current	$I_{VML}$	$E_C = 0\text{V}$ output open		35	70	mA
Output Limit Current	$I_{TL}$		560	700	840	mA
<b>Short Brake</b>						
On Voltage Range	$V_{SBON}$		3.5			V
OFF Voltage Range	$V_{SBOFF}$				1.5	V

Note: Not designed for radiation resistance.

## INPUT/OUTPUT CIRCUIT

### (1) Power Save

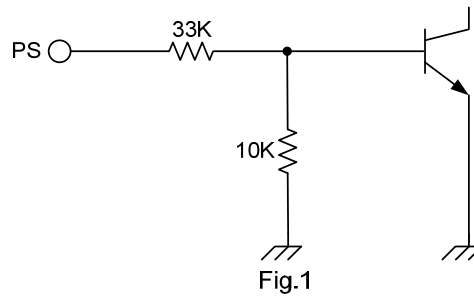

### (2) Torque Command Input

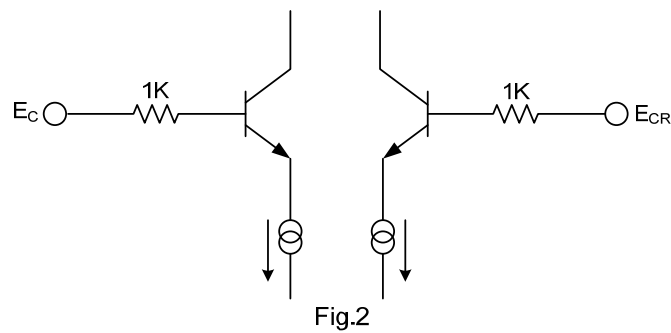

### (3) Torque Output (A1,A2,and A3)

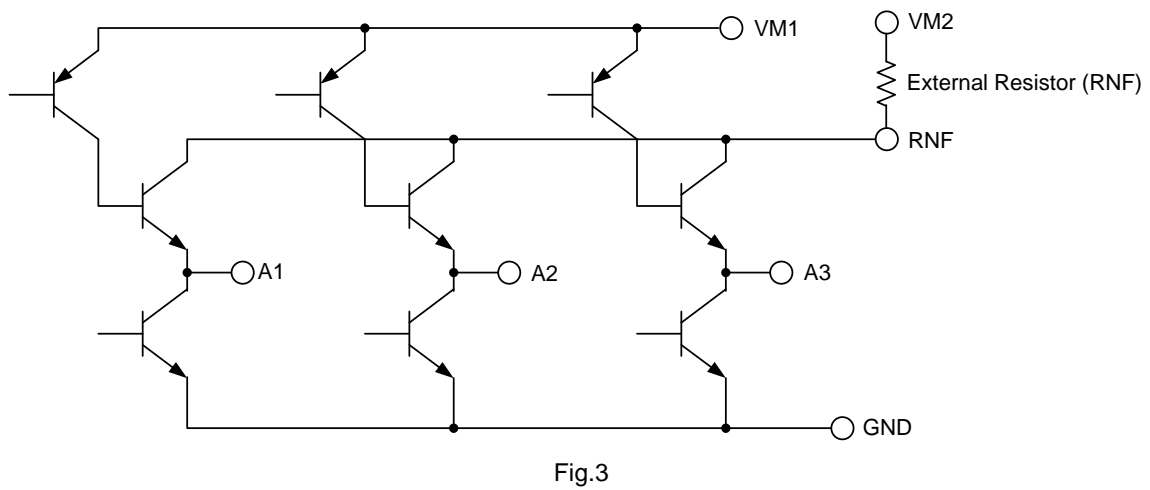

### (4) Hall Input (H1+,H1-,H2+,H2-,H3+,H3-)

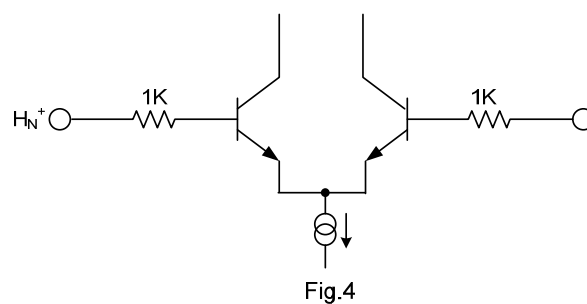

## ■ INPUT/OUTPUT CIRCUIT(Cont.)

### (5) Hall Bias

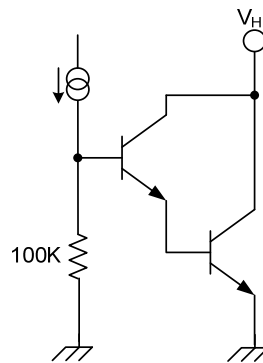

Fig.5

### (6) FG Output

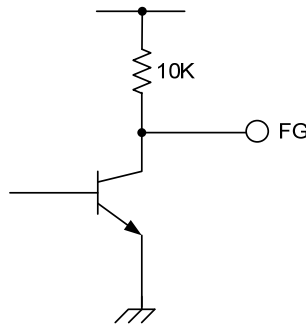

Fig.6

### (7) FR Output

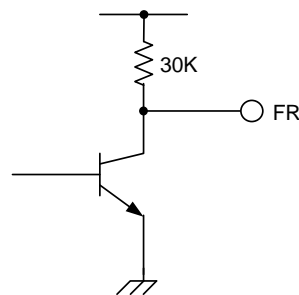

Fig.7

### (8) Short Brake

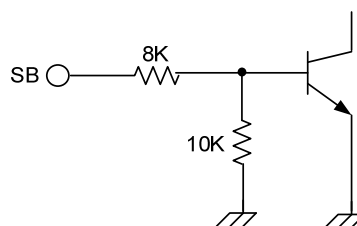

Fig.8

Note: Resistance values are typical values.

## ■ CIRCUIT OPERATION

### (1) Hall input to coil output

The phase relationship between the Hall input signals and the output current and voltage is shown in Fig.9. The motor position data input via the Hall pins is amplified by the Hall amplifier, and formed into waveforms by the matrix block. These signals are input to the output driver that supplies the drive current to the motor coils.

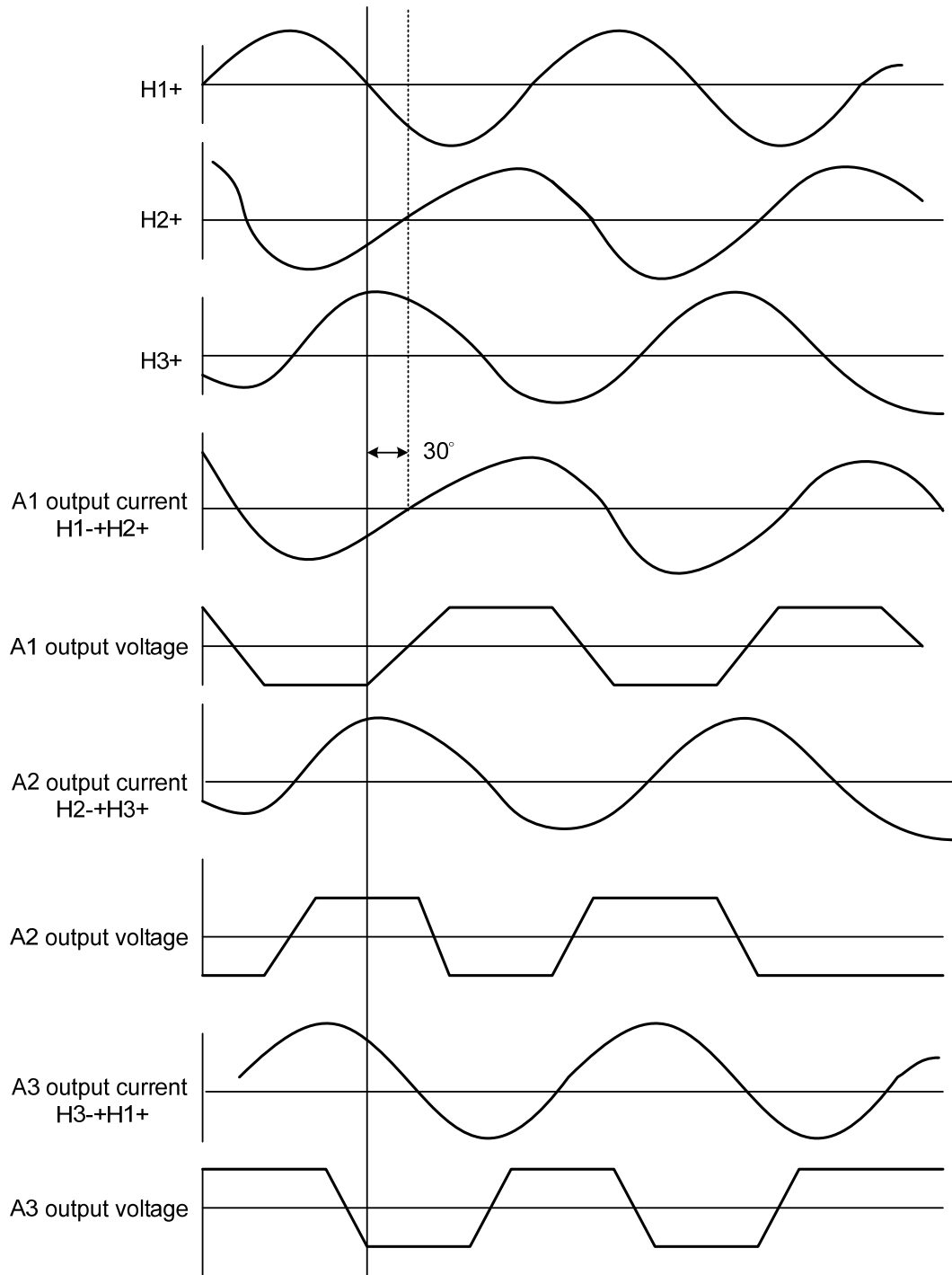

Fig.9



■ CIRCUIT OPERATION(Cont.)

(2) Torque command

The RNF pin voltage with respect to the torque command (EC) is as follows:

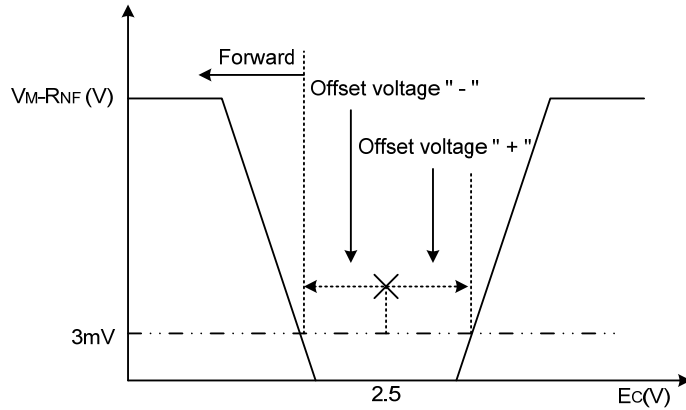

Fig.10

The I/O gain (GEC) from the EC pin to the RNF pin (output current) is determined by the RNF detector resistor.

$$GEC = 0.255 / RNF [A / V]$$

The torque limit current ITL is given by:  $ITL = 0.35 / RNF [A]$

ROTATION DIRECTION	
$E_c < E_{CR}$	FORWARD
$E_c > E_{CR}$	REVERSE(Note)

Note: Stops after detecting reverse

(3) Reverse rotation detection function

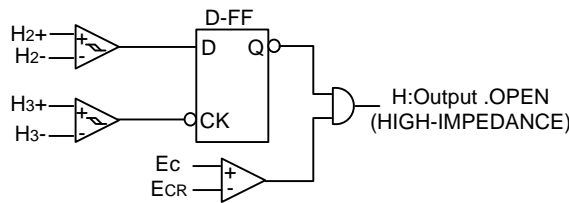

Fig.11

FR SIGNAL OUTPUT PIN	
FORWARD	L
REVERSE	H

The reverse detection circuit construction is shown in Fig.11.

(1) Forward ( $E_c < E_{CR}$ )

The phase relationship between the Hall input signals  $H_{2+}$  and  $H_{3+}$  becomes as shown in Fig.9, and the reverse rotation detection circuit does not operate.

(2) Reverse ( $E_c > E_{CR}$ )

The phase relationship between the signals  $H_{2+}$  and  $H_{3+}$  is opposite that for forward operation, and the reverse rotation detection circuit operates. The output goes OFF, and becomes open circuit.

(3) Short brake

When 3.5V or more is applied to the short brake pin, the upper-side output transistors of all go off, and the lowerside output transistors go on. Short braking operates regardless of the torque command signal.

(4) Other circuits

When 3.5V or more is applied to the power save pin, all circuits are on. When 1.5V or less is applied, the IC enters power save mode. Also, the Hall bias pins turn on and off with the power save pin.

■ TYPICAL APPLICATION

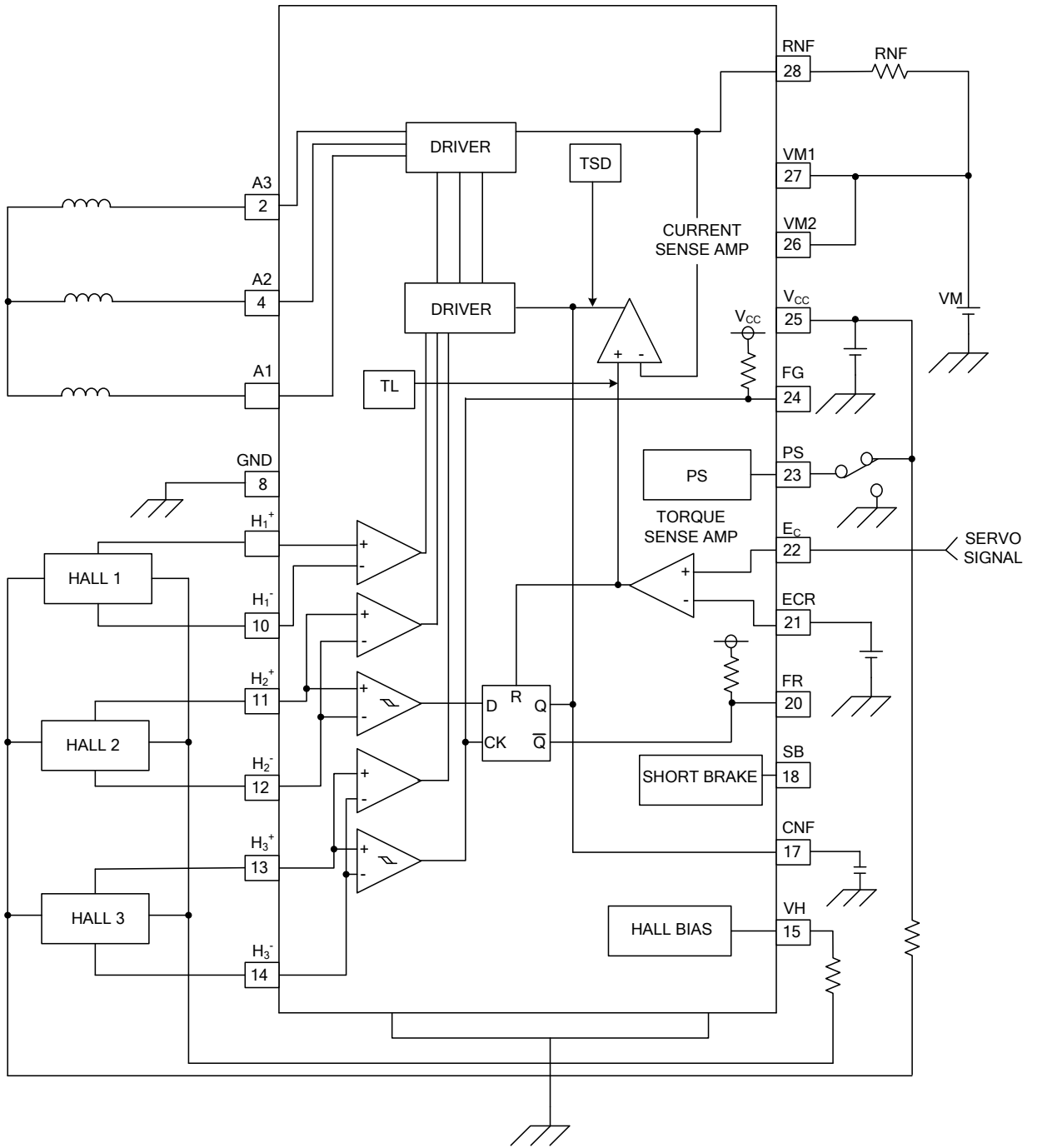

## ■ OPERATION NOTES

### (1) Power save

The power save input is an I / O circuit like the own shown in Fig.1.

The thermal derating characteristics of the power save pin is  $-8\text{mV} / ^\circ\text{C}$ , and the resistance will fluctuate between 30% so be careful of the input voltage range.

### (2) Hall input

The input circuit shown in Fig.4 is used for the Hall inputs.

The Hall elements can be connected either in series or in parallel.

### (3) Thermal shutdown (TSD)

When the junction temperature reaches  $175^\circ\text{C}$ , the A1, A2, and A3 coil outputs go open circuit. The thermal shutdown has approximately  $15^\circ\text{C}$  of hysteresis.

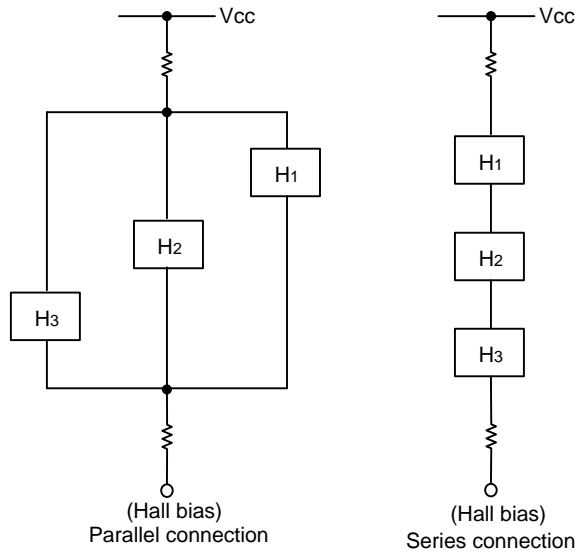

UTC assumes no responsibility for equipment failures that result from using products at values that exceed, even momentarily, rated values (such as maximum ratings, operating condition ranges, or other parameters) listed in products specifications of any and all UTC products described or contained herein. UTC products are not designed for use in life support appliances, devices or systems where malfunction of these products can be reasonably expected to result in personal injury. Reproduction in whole or in part is prohibited without the prior written consent of the copyright owner. The information presented in this document does not form part of any quotation or contract, is believed to be accurate and reliable and may be changed without notice.