



UC3842A/3843A

LINEAR INTEGRATED CIRCUIT

CURRENT MODE PWM CONTROL CIRCUITS

■ DESCRIPTION

The UTC **UC3842A/3843A** provide the necessary functions to implement off-line or DC to DC fixed frequency current mode , controlled switching circuits with minimal external components.

■ FEATURES

- *Low Start Up Current (Typical 0.12mA)
- *Automatic Feed Forward Compensation
- *Pulse-by-Pulse Current Limiting
- *Under-voltage Lockout with Hysteresis
- *Double Pulse Suppression
- *High Current Totem Pole Output to Drive MOSFET Directly
- *Internally Trimmed Band Gap Reference
- *500kHz Operation

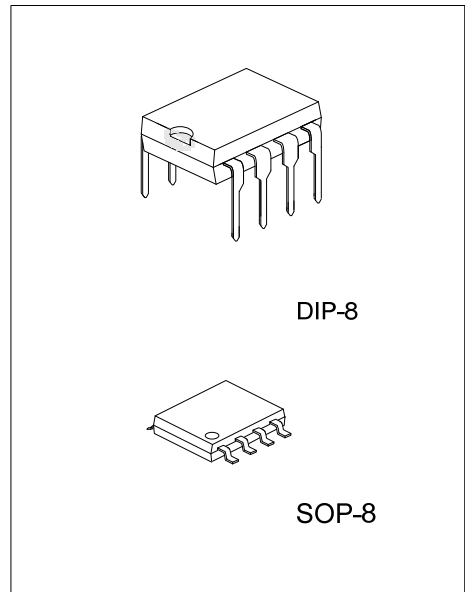

■ ORDERING INFORMATION

Ordering Number		Package	Packing
Lead Free	Halogen Free		
UC3842AL-D08-T	UC3842AP-D08-T	DIP-8	Tube
UC3842AL-S08-R	UC3842AP-S08-R	SOP-8	Tape Reel
UC3843AL-D08-T	UC3843AP-D08-T	DIP-8	Tube
UC3843AL-S08-R	UC3843AP-S08-R	SOP-8	Tape Reel

<p>UC3842AP-D08-T</p> <p>(1)Packing Type (2)Package Type (3)Green Package</p>	<p>(1) T: Tube, R: Tape Reel (2) D08: DIP-8, S08: SOP-8 (3) P: Halogen Free and Lead Free, L: Lead Free</p>
---------------------------------------------------------------------------------------	---------------------------------------------------------------------------------------------------------------------

■ MARKING

Package	UC3842A	UC3843A
DIP-8	<p>Date Code L: Lead Free P: Halogen Free Lot Code</p>	<p>Date Code L: Lead Free P: Halogen Free Lot Code</p>
SOP-8	<p>Date Code L: Lead Free P: Halogen Free Lot Code</p>	<p>Date Code L: Lead Free P: Halogen Free Lot Code</p>

■ PIN CONFIGURATION

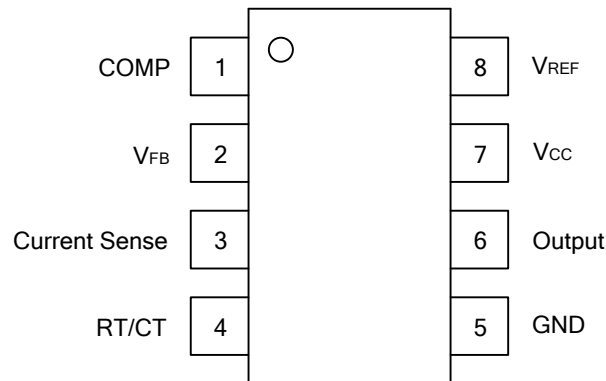

■ BLOCK DIAGRAM

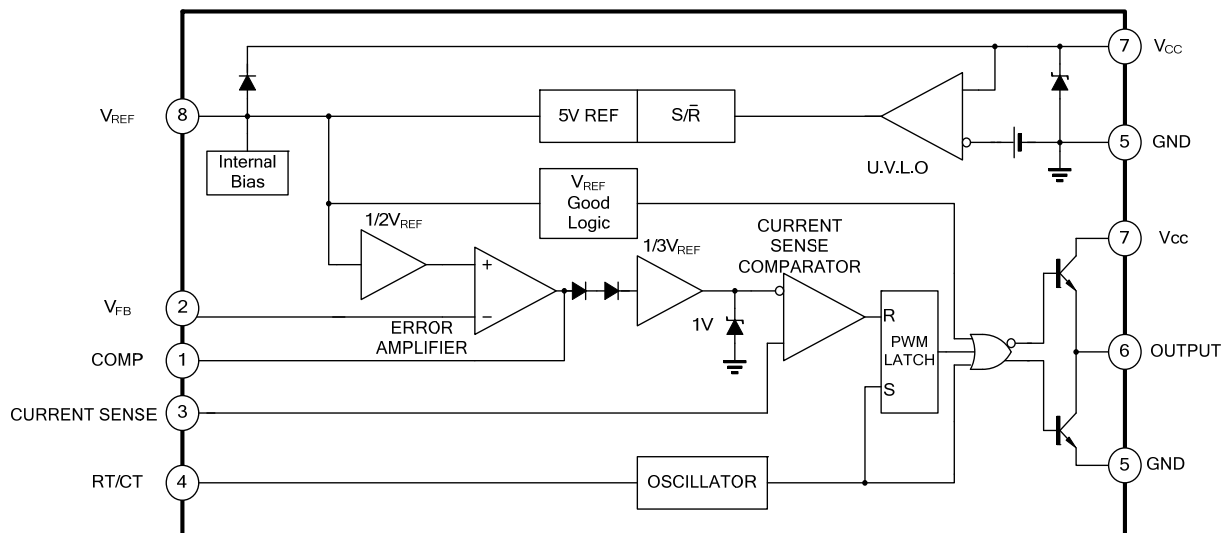

■ ABSOLUTE MAXIMUM RATINGS ($T_A=25^\circ\text{C}$, unless otherwise specified)

PARAMETER	SYMBOL	RATINGS	UNIT
Supply Voltage(Low Impedance Source)	V_{CC}	30	V
Supply Voltage($I_{CC}<30\text{mA}$)	V_{CC}	Self Limiting	V
Analog Inputs (Pin 2,3)	$V_{I(ANA)}$	-0.3 ~ +6.3	V
Output Current (Peak)	$I_{O(PEAK)}$	± 1	A
Error Amplifier Output Sink Current	$I_{SINK(EA)}$	10	mA
Output Energy (Capacity Load)		5	μJ
Power Dissipation($T_A \leq 25^\circ\text{C}$)	DIP-8	1250	mW
	SOP-8	800	
Derated at $T_A > 25^\circ\text{C}$		8	$\text{mW}/^\circ\text{C}$
Junction Temperature	T_J	+150	$^\circ\text{C}$
Storage Temperature	T_{STG}	-65 ~ +150	$^\circ\text{C}$

Note: Absolute maximum ratings are those values beyond which the device could be permanently damaged. Absolute maximum ratings are stress ratings only and functional device operation is not implied.

■ ELECTRICAL CHARACTERISTICS

($0^\circ\text{C} \leq T_A \leq 70^\circ\text{C}$, $V_{CC}=15\text{V}$, $R_T=10\text{k}\Omega$, $C_T=3.3\text{nF}$, unless otherwise specified)

PARAMETER	SYMBOL	TEST CONDITIONS	MIN	TYP	MAX	UNIT
REFERENCE SECTION						
Output Voltage	V_{REF}	$T_J=25^\circ\text{C}$, $I_{OUT}=1\text{mA}$	4.9	5	5.1	V
Line Regulation	ΔV_{REF}	$12 \leq V_{IN} \leq 25\text{V}$		6	20	mV
Load Regulation	ΔV_{REF}	$1 \leq I_{OUT} \leq 20\text{mA}$		6	25	mV
Temperature Stability		(Note 1)		0.2	0.4	$\text{mV}/^\circ\text{C}$
Total Output Variation		Line, Load, Temp (Note 1)	4.82		5.18	V
Output Noise Voltage	V_{OSC}	$10\text{Hz} \leq f \leq 10\text{kHz}$, $T_J=25^\circ\text{C}$ (Note 1)		50		μV
Long Term Stability		$T_A=25^\circ\text{C}$, 1000Hrs (Note 1)		5	25	mV
Output Short Circuit	I_{SC}		-30	-100	-180	mA
OSCILLATOR SECTION						
Initial Accuracy	f	$T_J=25^\circ\text{C}$	47	52	57	kHz
Voltage Stability	$\Delta f/\Delta V_{CC}$	$12 \leq V_{CC} \leq 25\text{V}$		0.2	1	%
Temperature Stability		$T_{MIN} \leq T_A \leq T_{MAX}$ (Note 1)		5		%
Amplitude	V_{OSC}	V_{PIN4} peak to peak		1.7		V
ERROR AMPLIFIER SECTION						
Input Voltage	$V_{I(EA)}$	$V_{PIN1}=2.5\text{V}$	2.42	2.50	2.58	V
Input Bias Current	$I_{I(BIAS)}$			-0.3	-2	μA
AVOL		$2\text{V} \leq V_{OUT} \leq 4\text{V}$	60	90		dB
Unity Gain Bandwidth		$T_J=25^\circ\text{C}$ (Note 1)	0.7	1		MHz
PSRR		$I_2 \leq V_{CC} \leq 25\text{V}$	60	70		dB
Output Sink Current	$I_{O(SINK)}$	$V_{PIN2}=2.7\text{V}$, $V_{PIN1}=1.1\text{V}$	2	6		mA
Output Source Current	$I_{O(SOURCE)}$	$V_{PIN2}=2.3\text{V}$, $V_{PIN1}=5\text{V}$	-0.5	-0.8		mA
V_{OUT} High	V_{OH}	$V_{PIN2}=2.3\text{V}$, $R_L=15\text{k}\Omega$ to GND	5	6		V
V_{OUT} Low	V_{OL}	$V_{PIN2}=2.7\text{V}$, $V_{PIN1}=1.1\text{V}$		0.7	1.1	V

■ ELECTRICAL CHARACTERISTICS(Cont.)

PARAMETER	SYMBOL	TEST CONDITIONS	MIN	TYP	MAX	UNIT	
CURRENT SENSE SECTION							
Gain	G_V	(Note 2, 3)	2.85	3	3.15	V/V	
Maximum Input signal	$V_{I(MAX)}$	$V_{PIN1}=5V$ (Note 2)	0.9	1	1.1	V	
PSRR		$12V \leq V_{CC} \leq 25V$		70		dB	
Input Bias Current	I_{BIAS}			-2	-10	μA	
Delay to Output		$V_{PIN3}=0$ to 2V		150	300	ns	
OUTPUT SECTION							
Output Level	Low	V_{OL}	$I_{O(SINK)}=20mA$		0.1	0.4	V
			$I_{O(SINK)}=200mA$		1.5	2.2	V
	High	V_{OH}	$I_{O(SOURCE)}=20mA$	13	13.5		V
			$I_{O(SOURCE)}=200mA$	12	13.5		V
Rise Time	t_R	$T_J=25^\circ C, C_L=1nF$ (Note 1)		50	150	ns	
Fall Time	t_F	$T_J=25^\circ C, C_L=1nF$ (Note 1)		50	150	ns	
UNDER-VOLTAGE LOCKOUT OUTPUT SECTION							
Start Threshold	3842A	$V_{TH(ST)}$		14.5	16	17.5	V
	3843A			7.8	8.4	9	V
Min. Operating Voltage	3842A	$V_{OPR(MIN)}$	After Turn On	8.5	10	11.5	V
	3843A			7	7.6	8.2	V
PWM SECTION							
Duty Cycle	MAX	$D_{(MAX)}$		95	97	100	%
	MIN	$D_{(MIN)}$				0	%
TOTAL STANDBY CURRENT							
Start-up Current	I_{ST}			0.12	0.3	mA	
Operating Supply Current	$I_{CC(OPR)}$	$V_{PIN2}=V_{PIN3}=0V$		11	17	mA	
V_{CC} Zener Voltage	V_Z	$I_{CC}=25mA$		34		V	

Notes: 1. These parameters, although guaranteed, are not 100% tested in production.

2. Parameters measured at trip point of latch with $V_{PIN2}=0$.

3. Gain defined as:

$$A = \frac{\Delta V_{PIN1}}{\Delta V_{PIN3}} ; 0 \leq V_{PIN3} \leq 0.8V$$

4. Adjust V_{CC} above the start threshold before setting at 15V.

■ OPEN-LOOP LABORATORY TEST FIXTURE

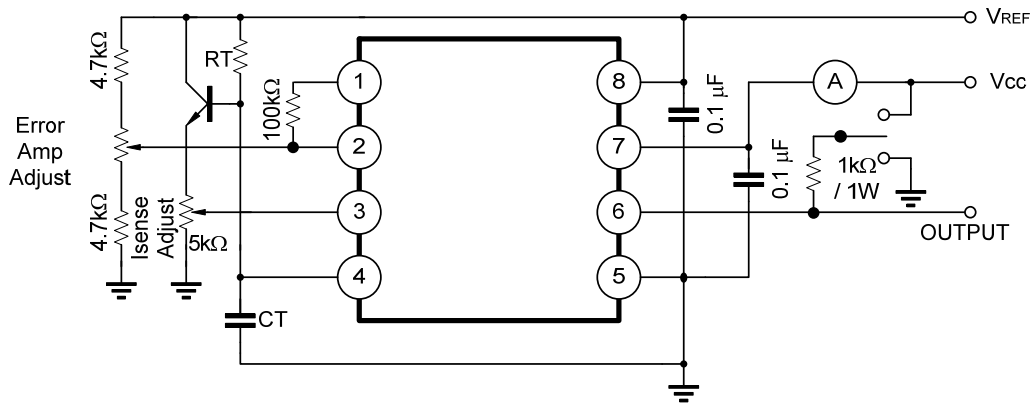

High peak current associated with capacity loads necessitate careful grounding techniques. Timing and bypass capacitors should be connected close to Pin 5 in single point GND. The transistor and 5kΩ potentiometer are used to sample the oscillator waveform and apply an adjustable Ramp to Pin 3.

■ UNDER-VOLTAGE LOCKOUT

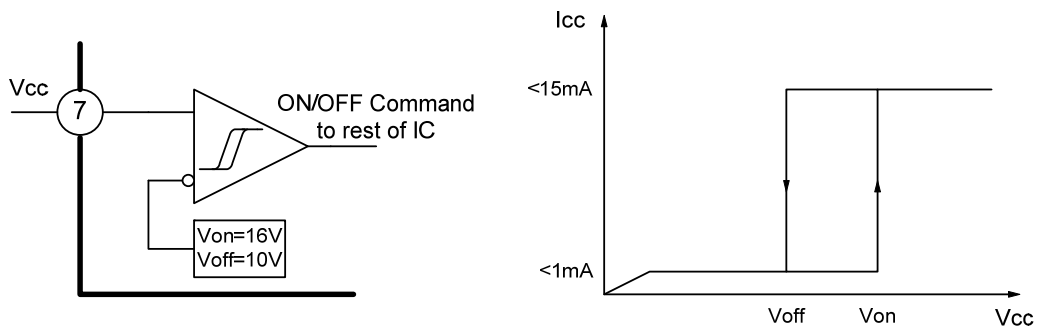

During Under-Voltage Lockout, the output driver is biased to a high impedance state. Pin 6 should be shunt to GND with a bleeder resistor to prevent activating the power switch with output leakage currents.

■ ERROR AMPLIFIER CONFIGURATION

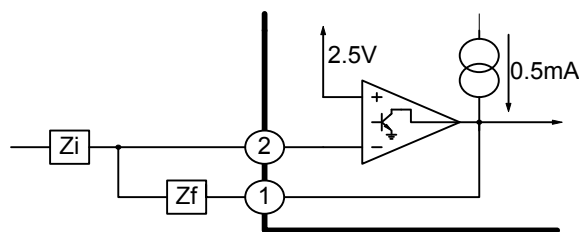

Error amplifier can source or sink up to 0.5mA

■ CURRENT SENSE CIRCUIT

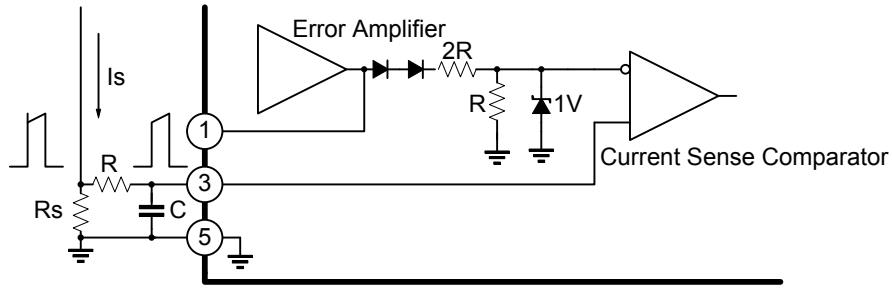

Peak current (I_s) determined by the formula: $I_{S_{MAX}} = 1.0V/R_s$.
A small RC filter be required to suppress switch transients.

■ SLOPE COMPENSATION

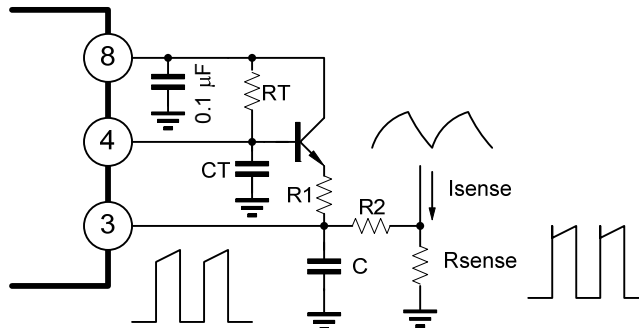

A fraction of the oscillator ramp can be resistively summed with the current sense signal to provide slope compensation for converts requiring duty cycles over 50%. Note that capacitor C, forms a filter with R2 to suppress the leading edge switch spikes.

■ OSCILLATOR SECTION

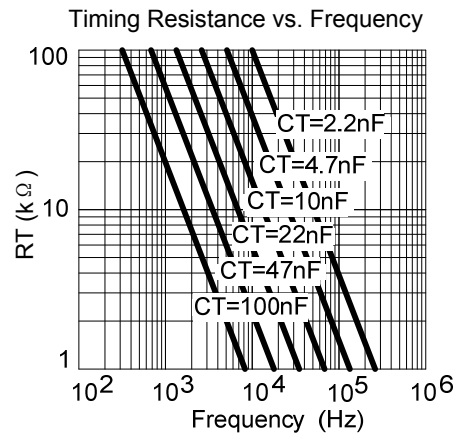
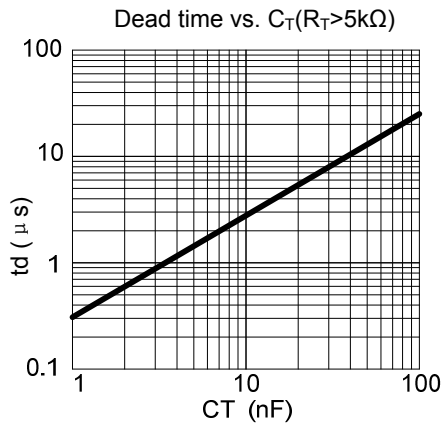
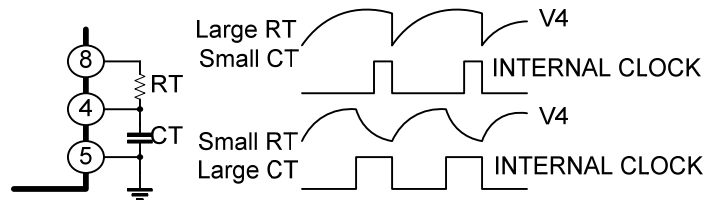

■ SHUTDOWN TECHNIQUES

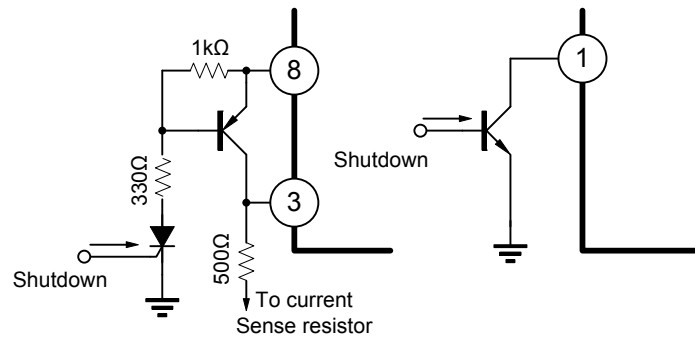

Shutdown UTC **UC3842A** can be accomplished by two methods; either raise Pin 3 above 1V or pull Pin 1 below a voltage two diode drops above ground. Either method caused the output of PWM comparator to be high (refer to block diagram). The PWM latch is reset dominant so that the output will remain low until the next clock cycle after the shutdown condition at Pins 1 and/or 3 is removed. In one example, an externally latched shut-down may be accomplished by adding an SCR which be reset by cycling V_{CC} below the lower UVLO threshold. At this point the reference turns off allowing the SCR to reset.

■ TYPICAL CHARACTERISTICS

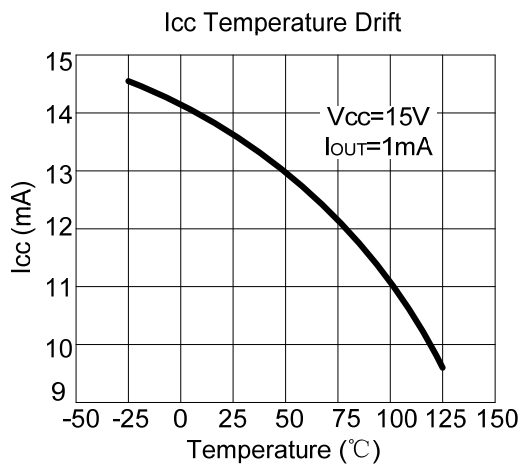
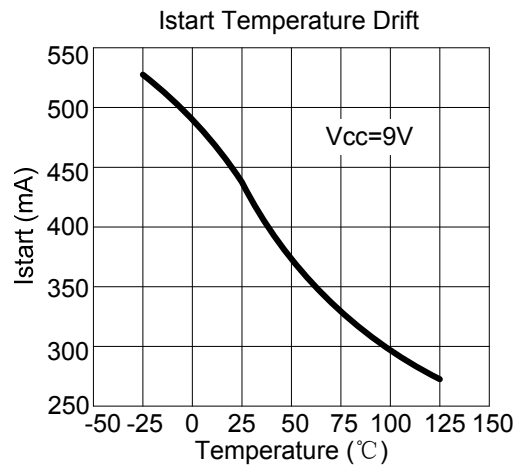
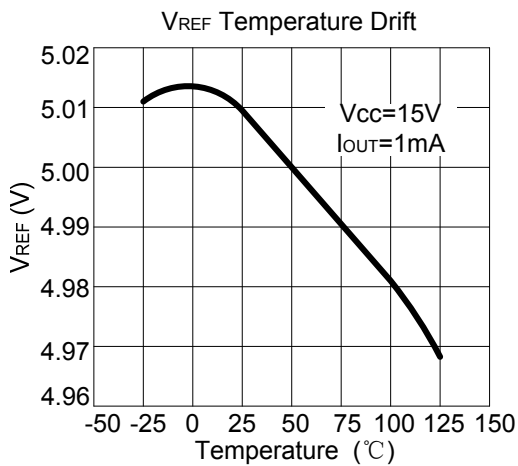
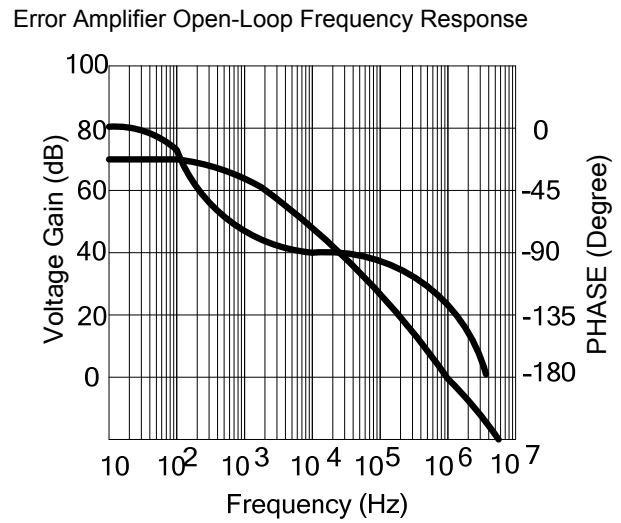
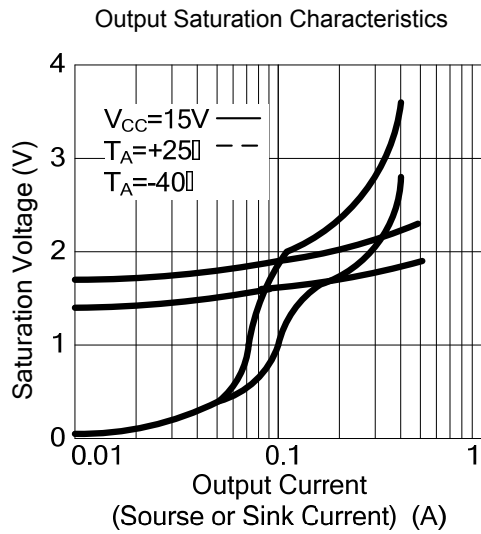

UTC assumes no responsibility for equipment failures that result from using products at values that exceed, even momentarily, rated values (such as maximum ratings, operating condition ranges, or other parameters) listed in products specifications of any and all UTC products described or contained herein. UTC products are not designed for use in life support appliances, devices or systems where malfunction of these products can be reasonably expected to result in personal injury. Reproduction in whole or in part is prohibited without the prior written consent of the copyright owner. UTC reserves the right to make changes to information published in this document, including without limitation specifications and product descriptions, at any time and without notice. This document supersedes and replaces all information supplied prior to the publication hereof.