



# 100mΩ POWER DISTRIBUTION SWITCHES

### DESCRIPTION

The **US202/A** is a power distribution switch. It is particularly suitable for self-powered and bus-powered USB (Universal Series bus) applications. It has 28μA low quiescent supply current that meets the requirements of battery-powered portable equipments.

A built-in charge pump is used to drive the N-channel N-MOSFET that is free of parasitic body diode to eliminate any reversed current flow across the switch when it is powered off.

The **US202/A** incorporates some protection circuits such as current limit and short protection circuits, soft start circuit, thermal shutdown and UVLO (Under-voltage Lockout) protection circuits. The thermal shutdown circuits protect this device from damage when over current occurs, and the soft start circuits are used to prevent inrush current when plug-in event occurs.

The **US202/A** can be used in such applications such as battery-powered equipments, motherboard USB power switches, USB device power switches, hot-plug power supplies, battery-charger circuits and so on.

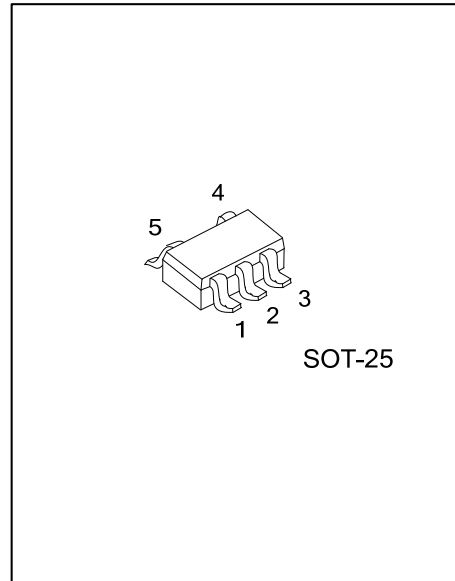

### FEATURES

- \* Input Voltage Varies From 2.7V to 5.5V
- \* Guaranteed Continuous Current: 1.0A/2.0A
- \* High-Side NMOSFET: 85mΩ (TYP)
- \* Soft Start
- \* Current Limit: 1.5A/2.5A
- \* Thermal Protection
- \* Low Supply Current: 28μA

### ORDERING INFORMATION

Ordering Number		Package	Packing
Lead Free	Halogen Free		
US202XL-AF5-R	US202XG-AF5-R	SOT-25	Tape Reel
US202AXL-AF5-R	US202AXG-AF5-R	SOT-25	Tape Reel

<p>US202XXG-AF5-R</p>	<p>(1) R: Tape Reel  (2) AF5: SOT-25  (3) G: Halogen Free and Lead Free  (4) H: Active High, L: Active Low  (5) Blank: 1.5A, A: 2.5A</p>
-----------------------	--

MARKING

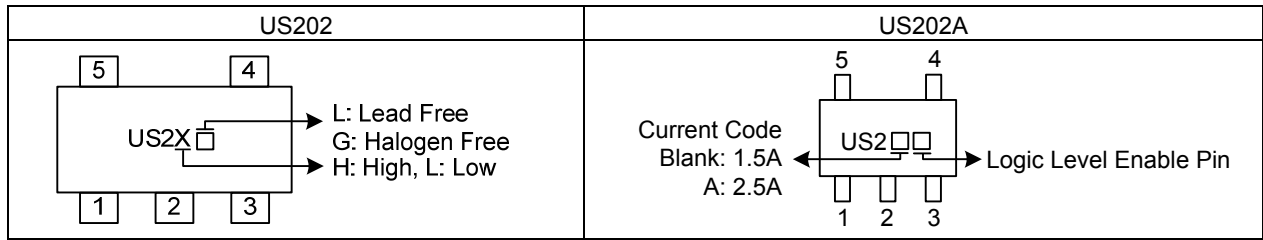

PIN CONFIGURATION

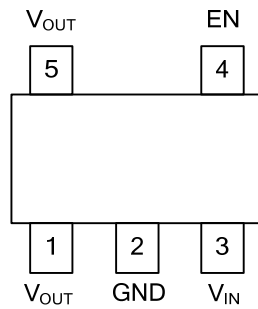

PIN DESCRIPTION

PIN NO.	PIN NAME	DESCRIPTION
1, 5	$V_{OUT}$	Output Voltage
2	GND	Ground
3	$V_{IN}$	Power Input
4	EN	Chip Enable (Active High)

BLOCK DIAGRAM

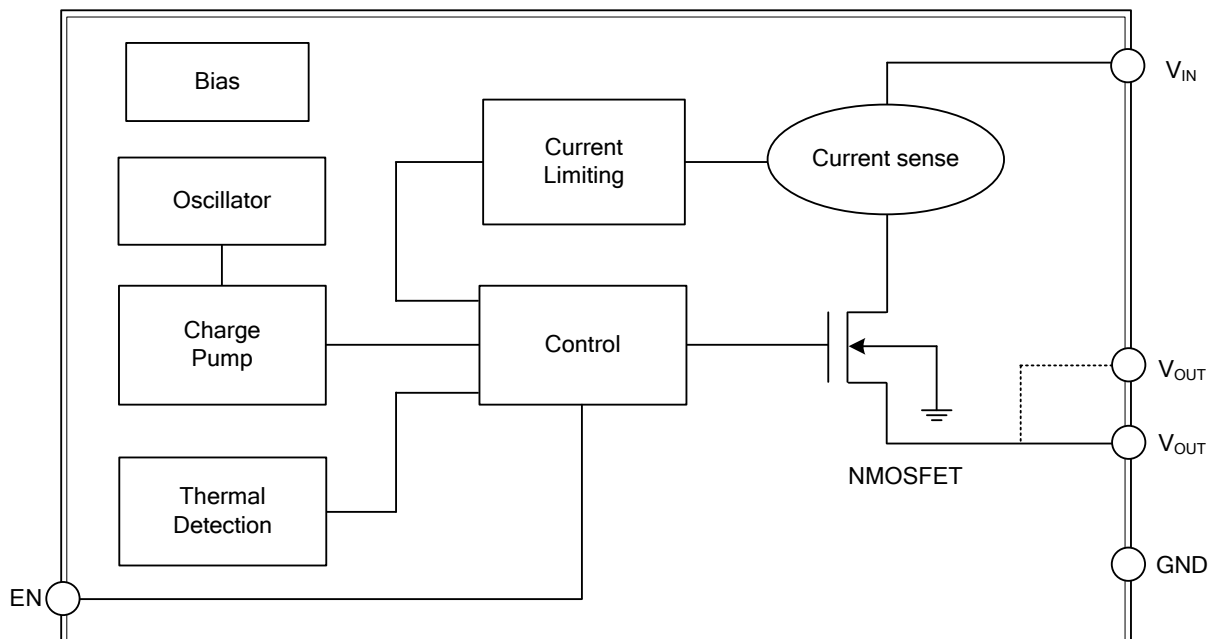

### ■ ABSOLUTE MAXIMUM RATING

PARAMETER	SYMBOL	RATINGS	UNIT
Supply Voltage	$V_{IN}$	6	V
Chip Enable	$V_{CE}$	-0.3 ~ 6	V
Power Dissipation ( $T_A = 25^\circ\text{C}$ )	$P_D$	0.25	W
Junction Temperature	$T_J$	-20 ~ 100	$^\circ\text{C}$
Storage Temperature	$T_{STG}$	-65 ~ 150	$^\circ\text{C}$

Note: Absolute maximum ratings are those values beyond which the device could be permanently damaged. Absolute maximum ratings are stress ratings only and functional device operation is not implied.

### ■ ELECTRICAL CHARACTERISTICS

( $V_{IN} = 5\text{V}$ ,  $C_{IN} = C_{OUT} = 1\mu\text{F}$ ,  $T_A = 25^\circ\text{C}$ , unless otherwise specified)

PARAMETER	SYMBOL	TEST CONDITIONS	MIN	TYP	MAX	UNIT
Input Voltage Range	$V_{IN}$		2.7		5.5	V
Output NMOSFET $R_{DS(ON)}$	$R_{DS(ON)}$	$I_L = 1\text{A}$		85	100	$\text{m}\Omega$
Supply Current		$V_{IN} = 5\text{V}$		28	65	$\mu\text{A}$
Output Turn-On Rising Time	$T_R$	$R_L = 10\Omega$ , 90% Settling		400		$\mu\text{S}$
Current Limit Threshold	$I_{LIMIT}$	US202	1.1	1.5	2.0	A
		US202A	2.1	2.5	3.2	A
Short-Circuit Fold Back Current	$I_{SC(FB)}$	$V_{OUT} = 0\text{V}$ , measured prior to thermal shutdown		1.0		A
EN Input High Threshold	$V_{IH}$		2.0			V
EN Input Low Threshold	$V_{IL}$				0.8	V
Shutdown Supply Current	$I_{OFF}$	EN = "0"		0.1	1.0	$\mu\text{A}$
Output Leakage Current	$I_{I(LEAK)}$	EN = "0", $V_{OUT} = 0\text{V}$		0.5	10	$\mu\text{A}$
$V_{IN}$ Under Voltage Lockout	UVLO		1.3	1.8		V
$V_{IN}$ Under Voltage Hysteresis				100		mV
Thermal Limit	$T_{SD}$			130		$^\circ\text{C}$
Thermal Limit Hysteresis	$\Delta T_{SD}$			20		$^\circ\text{C}$

## ■ APPLICATION INFORMATION

The UTC **US202/A** is a high-side single N-Channel MOSFET switch with active-high enable input.

### Input and Output

$V_{IN}$  pin (input) is the power supply connection to the circuitry and the drain of the output MOSFET.  $V_{OUT}$  pin (output) is the source of the output MOSFET. In a typical circuit, current flows through the switch from  $V_{IN}$  to  $V_{OUT}$  toward the load. Both  $V_{OUT}$  pins must be short on the board and connected to the load and so do both  $V_{IN}$  pins but connected to the power source.

### Thermal Shutdown

Thermal shutdown is used to turn off the output MOSFET when the if the temperature is higher than  $130^{\circ}\text{C}$ ,  $20^{\circ}\text{C}$  of hysteresis prevents the switch turn on until the die temperature drops to  $110^{\circ}\text{C}$ .

### Soft Start

When hot-plug events occur, the soft start is used to eliminate the upstream voltage droop due to the inrush current. The soft-start protects power supplies from damage caused by highly capacitive loads.

### Under-Voltage Lockout

UVLO (Under voltage Lockout) turn off the MOSFET switch once the input voltage falls below 1.8V (TYP.) and if the input voltage exceeds 1.8V, the switch will be turned on.

### Current Limiting and Short Protection

The current limit threshold is preset internally. The minimum value is 1.1A/2.1A. The current limit circuit protects this device from damage resulting from undesired excess inrush current, which is encountered during hot plug-in events. The output current is limited to approximately 1.5A/2.5A (TYP). When the output is short to ground, it will limit to a constant current 1A until thermal shutdown or short condition removed.

### Filtering

During the hot-plug events, in order to limit the input voltage drop, a  $1\mu\text{F}$  ceramic capacitor is recommended to be placed between  $V_{IN}$  to GND. However special care must be taken to the values of the capacitor, because higher capacitor values will further reduce the voltage drop at the input.

In order to prevent inductive parasitic from pulling  $V_{OUT}$  negative during turn-off or EMI damage to other components during the hot detachment, it's better to connect a sufficient capacitor from  $V_{OUT}$  to GND. This capacitor is also necessary for meeting the USB specification during hot plug-in operation.

If the UTC **US202/A** is implanted in device and application, minimum  $1\mu\text{F}$  capacitor from  $V_{OUT}$  to GND is recommended. If the  $V_{OUT}$  is short to ground frequently during usage, large size input capacitor is necessary, recommend  $22\mu\text{F}$ .

Choosing these capacitors properly is critical. A lower ESR on the capacitor can get a lower IR drop during the operation, so the Effective Series Resistance (ESR) of the capacitors must be considered.

For ferrite beads, if they are in series with all power and ground lines, the EMI will be eliminated or reduced. The DC resistance of the wire kept to a minimum to reduce the voltage drop should be considered in choosing ferrite beads.

## ■ APPLICATION INFORMATION (Cont.)

### Reverse Current Preventing

Since the UTC US202/A's MOSFET is bi-directional, it allows the voltage on  $V_{OUT}$  pin is higher than that on  $V_{IN}$  pin. In order to avoid reverse current occur, turn off this switch or connect  $V_{IN}$  to a fixed voltage less than 1.3V.

### Layout and Thermal Dissipation

The switch should be placed as close to the USB connector as possible and all traces should be as short as possible to reduce the effect of undesirable parasitic inductance.

Also, place the output capacitor and ferrite beads to the USB connector as close to as possible.

If ferrite beads are used, use wires kept to a minimum resistance and large solder pads to minimize connection resistance.

If the package is with dual  $V_{OUT}$  or  $V_{IN}$  pins, short both the same function pins as Fig.1 or Fig.2 to reduce the internal turn-on resistance. If the output power is delivered to two individual ports, it is specially necessary to short both  $V_{OUT}$  pin at the switch output side in order to protect the switch when each port are plug-in separately.

Under normal operating conditions, the package can dissipate the channel heat away. Wide power bus planes connected to  $V_{IN}$  and  $V_{OUT}$  and a ground plane in contact with the device will help dissipate additional heat.

## ■ TYPICAL APPLICATION CIRCUIT

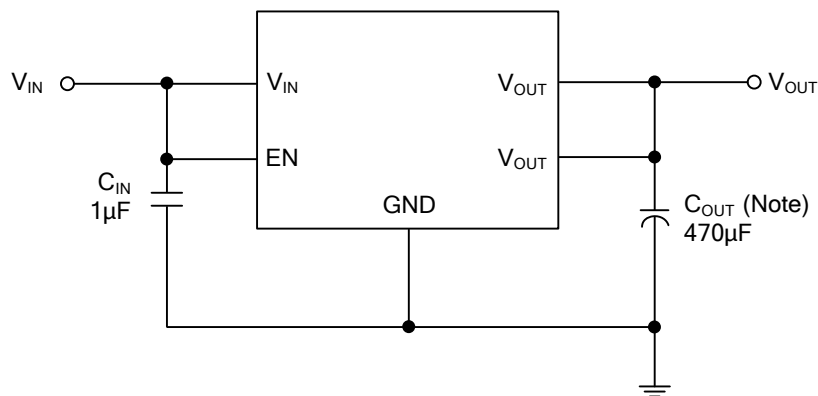

Note: 470µF, Low ESR Electrolytic

UTC assumes no responsibility for equipment failures that result from using products at values that exceed, even momentarily, rated values (such as maximum ratings, operating condition ranges, or other parameters) listed in products specifications of any and all UTC products described or contained herein. UTC products are not designed for use in life support appliances, devices or systems where malfunction of these products can be reasonably expected to result in personal injury. Reproduction in whole or in part is prohibited without the prior written consent of the copyright owner. UTC reserves the right to make changes to information published in this document, including without limitation specifications and product descriptions, at any time and without notice. This document supersedes and replaces all information supplied prior to the publication hereof.