



2SB824

PNP SILICON TRANSISTOR

PNP PLANAR SILICON TRANSISTOR

FEATURES

- * Low collector-to-emitter saturation voltage:
 $V_{CE(SAT)} = -0.4V \text{ max} / I_C = -3A, I_B = -0.3A$

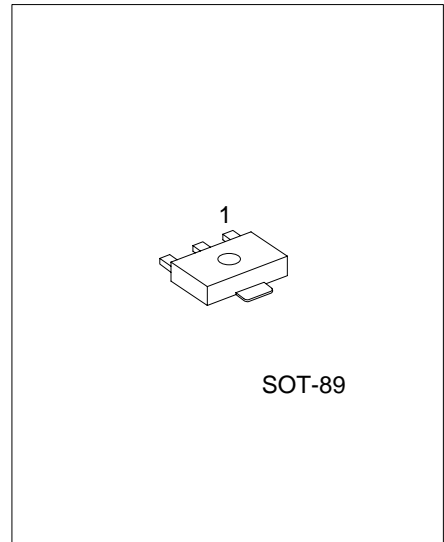

*Pb-free plating product number: 2SB824L

ORDERING INFORMATION

Ordering Number		Package	Pin Assignment			Packing
Normal	Lead Free Plating		1	2	3	
2SB824-x-AB3-R	2SB824L-x-AB3-R	SOT-89	B	C	E	Tape Reel

<p>2SB824L-x-AB3-R</p>	<ul style="list-style-type: none"> (1) R: Tape Reel (2) AB3: SOT-89 (3) x: refer to Classification of h_{FE1} (4) L: Lead Free Plating, Blank: Pb/Sn
------------------------	---

■ ABSOLUTE MAXIMUM RATINGS (Ta=25)

PARAMETER	SYMBOL	RATINGS	UNIT
Collector to Base Voltage	V_{CBO}	-60	V
Collector to Emitter Voltage	V_{CEO}	-50	V
Emitter to Base Voltage	V_{EBO}	-6	V
Collector Current	I_C	-5	A
Collector Current (Pulse)	I_{CP}	-9	A
Collector Dissipation	P_C	500	mW
Junction Temperature	T_J	+150	
Storage Temperature	T_{STG}	-40 ~ +150	

Note: Absolute maximum ratings are those values beyond which the device could be permanently damaged. Absolute maximum ratings are stress ratings only and functional device operation is not implied.

■ ELECTRICAL CHARACTERISTICS (Ta=25)

PARAMETER	SYMBOL	TEST CONDITIONS	MIN	TYP	MAX	UNIT
Collector-to-Base Breakdown Voltage	BV_{CBO}	$I_C = -1mA, I_E = 0$	-60			V
Collector-to-Emitter Breakdown Voltage	BV_{CEO}	$I_C = -1mA, R_{BE} = \infty$	-50			V
Emitter-to-Base Breakdown Voltage	BV_{EBO}	$I_C = 0, I_E = -1mA$	-6			V
Collector Cut-Off Current	I_{CBO}	$V_{CB} = -40V, I_E = 0$			-0.1	mA
Emitter Cut-Off Current	I_{EBO}	$V_{EB} = -4V, I_C = 0$			-0.1	mA
DC Current Gain	h_{FE1}	$V_{CE} = -2V, I_C = -1A$	70		360	
	h_{FE2}	$V_{CE} = -2V, I_C = -3A$	30			
Gain Bandwidth Product	f_T	$V_{CE} = -5V, I_C = -1A$		30		MHZ
Output Capacitance	C_{ob}	$V_{CB} = -10V, f = 1MHz$		100		pF
Collector-to-Emitter Saturation Voltage	$V_{CE(SAT)}$	$I_C = -3A, I_B = -0.3A$			-0.4	V
Turn-ON Time	t_{ON}	See specified test circuit		0.1		μs
Storage Time	t_{STG}	See specified test circuit		1.4		μs
Fall Time	t_F	See specified test circuit		0.2		μs

■ CLASSIFICATION of h_{FE1}

RANK	Q	R	S
RANGE	70-140	100-200	180-360

■ SWITCHING TIME TEST CIRCUIT

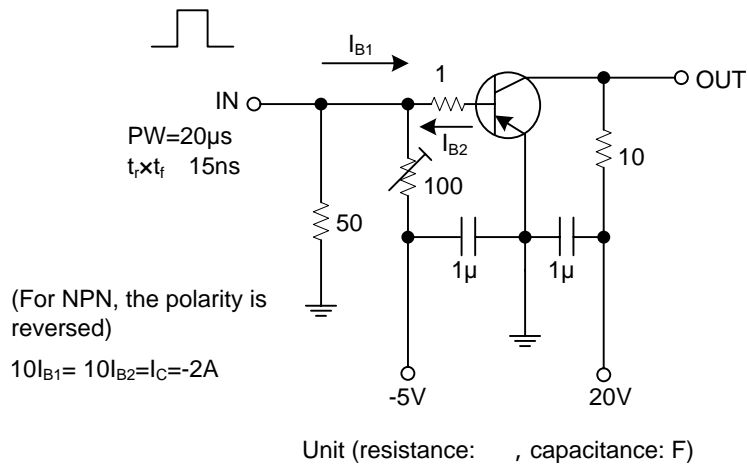

TYPICAL CHARACTERISTICS

Collector Current vs. Collector-to-Emitter Voltage

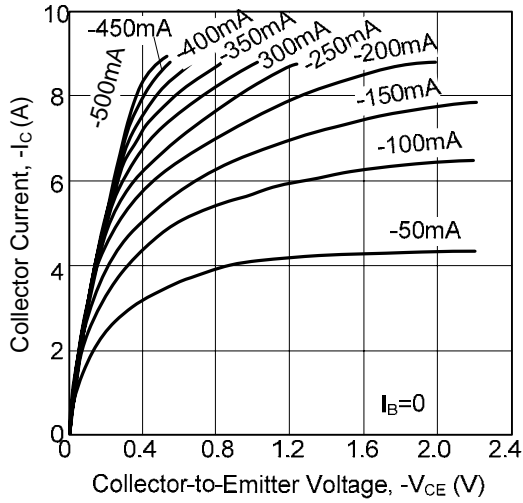

Collector Current vs. Base-to-Emitter Voltage

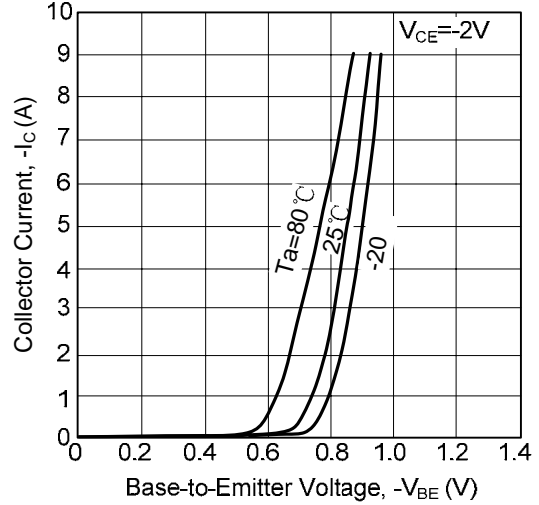

DC Current Gain vs. Collector Current

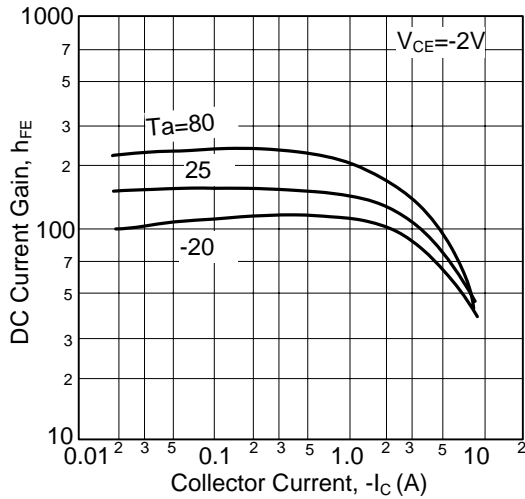

Collector-Emitter Saturation Voltage vs. Collector Current

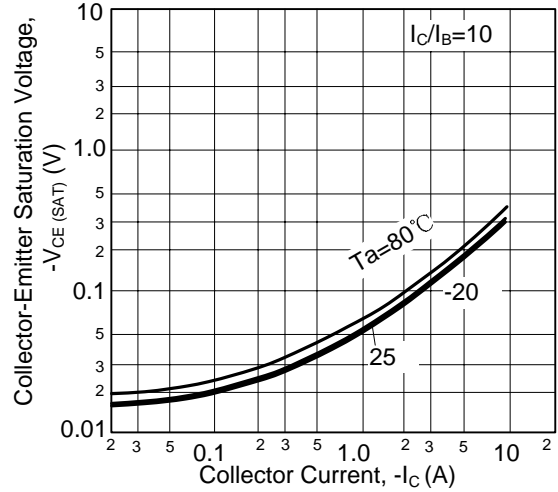

Collector-Emitter Saturation Voltage vs. Collector Current

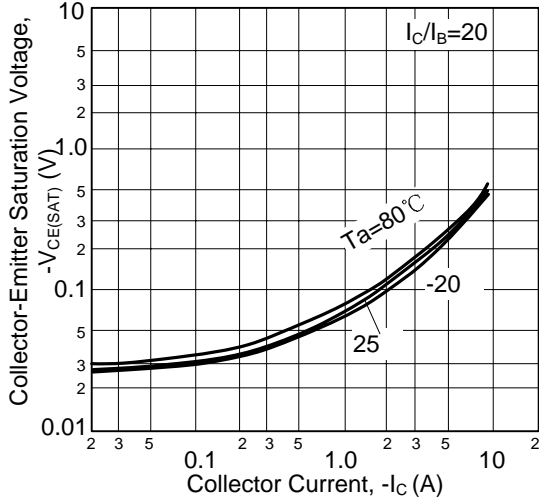

Base-Emitter Saturation Voltage vs. Collector Current

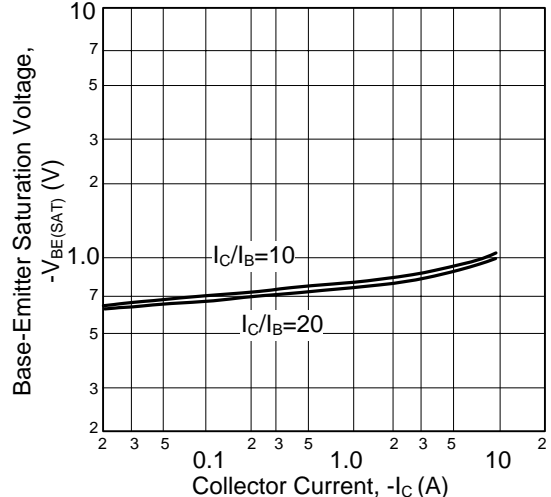

■ TYPICAL CHARACTERISTICS(Cont.)

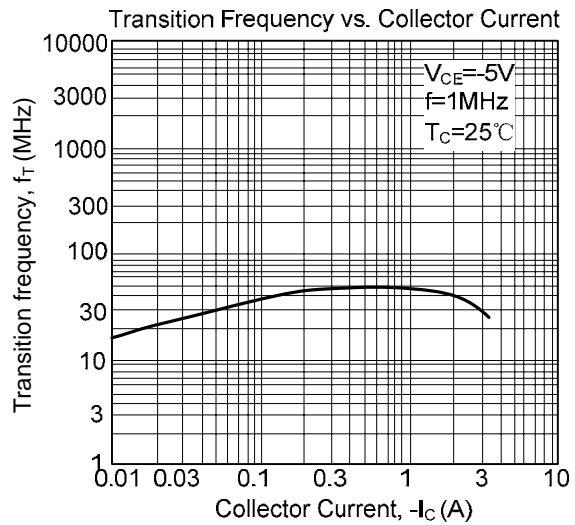
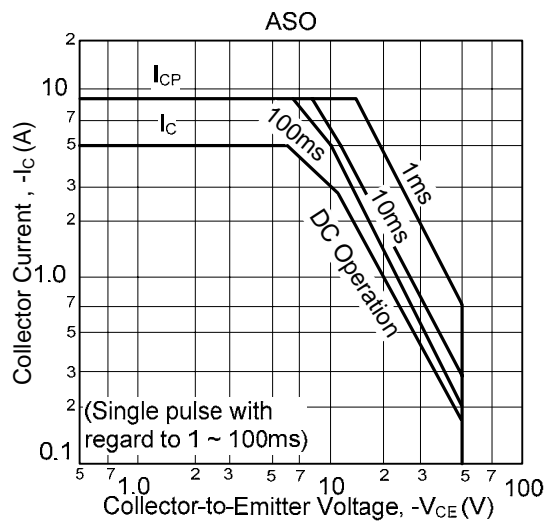

UTC assumes no responsibility for equipment failures that result from using products at values that exceed, even momentarily, rated values (such as maximum ratings, operating condition ranges, or other parameters) listed in products specifications of any and all UTC products described or contained herein. UTC products are not designed for use in life support appliances, devices or systems where malfunction of these products can be reasonably expected to result in personal injury. Reproduction in whole or in part is prohibited without the prior written consent of the copyright owner. The information presented in this document does not form part of any quotation or contract, is believed to be accurate and reliable and may be changed without notice.