



2SD1816

NPN PLANAR TRANSISTOR

HIGH CURRENT SWITCHING APPLICATIONS

■ FEATURES

- * Low collector-to-emitter saturation voltage
- * Good linearity of h_{FE}
- * Small and slim package facilitating compactness of sets.
- * High f_T
- * Fast switching speed

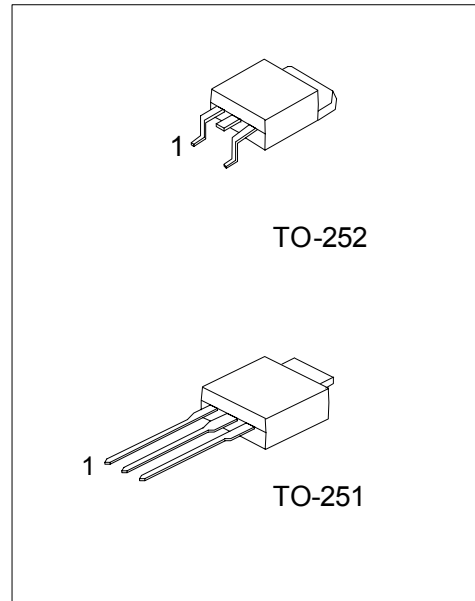

*Pb-free plating product number: 2SD1816L

■ ORDERING INFORMATION

Order Number		Package	Pin Assignment			Packing
Normal	Lead Free Plating		1	2	3	
2SD1816-x-TM3-T	2SD1816L-x-TM3-T	TO-251	B	C	E	Tube
2SD1816-x-TN3-T	2SD1816L-x-TN3-T	TO-252	B	C	E	Tube
2SD1816-x-TN3-R	2SD1816L-x-TN3-R	TO-252	B	C	E	Tape Reel

<p>2SD1816L-x-TM3-T</p>	<p>(1) Packing Type (2) Package Type (3) Rank (4) Lead Plating</p>	<p>(1) T: Tube, R: Tape Reel (2) TM3: TO-251, TN3: TO-252 (3) x: refer to Classification of h_{FE1} (4) L: Lead Free Plating, Blank: Pb/Sn</p>
-------------------------	--	---

2SD1816

NPN PLANAR TRANSISTOR

■ ABSOLUTE MAXIMUM RATINGS (Ta =25)

PARAMETER	SYMBOL	RATINGS	UNIT
Collector-Base Voltage	V_{CBO}	120	V
Collector-Emitter Voltage	V_{CEO}	100	V
Emitter-Base Voltage	V_{EBO}	6	V
Collector Current	DC	4	A
	PULSE(Note 1)	8	A
Collector Power Dissipation	P_D	1	W
		(T _C =25°C) 20 (Note 2)	W
Junction Temperature	T _J	+150	°C
Storage Temperature	T _{STG}	-40 ~ +150	°C

Note1: Duty=1/2, Pw=20ms

Note2: When mounted on a 40×40×0.7mm ceramic board

Note3: Absolute maximum ratings are those values beyond which the device could be permanently damaged.
Absolute maximum ratings are stress ratings only and functional device operation is not implied.

■ ELECTRICAL CHARACTERISTICS (Ta=25°C, unless otherwise specified)

PARAMETER	SYMBOL	TEST CONDITIONS	MIN	TYP	MAX	UNIT
Collector Base Breakdown Voltage	BV_{CBO}	$I_C = 10\mu A, I_E = 0$	120			V
Collector Emitter Breakdown Voltage	BV_{CEO}	$I_C = 1mA, R_B = \infty$	100			V
Emitter Base Breakdown Voltage	BV_{EBO}	$I_E = 10\mu A, I_C = 0$	6			V
Base-Emitter Saturation Voltage	$V_{BE(SAT)}$	$I_C = 2A, I_B = 0.2A$		0.9	1.2	V
Collector-Emitter Saturation Voltage	$V_{CE(SAT)}$	$I_C = 2A, I_B = 0.2A$		150	400	mV
Collector Cut-Off Current	I_{CBO}	$V_{CB} = 100V, I_E = 0$			1	μA
Emitter Cut-Off Current	I_{EBO}	$V_{EB} = 4V, I_C = 0$			1	μA
DC Current Transfer Ratio	h_{FE1}	$V_{CE} = 5V, I_C = 0.5A$	70		400	
	h_{FE2}	$V_{CE} = 5V, I_C = 3A$	40			
Transition Frequency	f_T	$V_{CE} = 10V, I_C = 0.5A$		180		MHz
Output Capacitance	C_{ob}	$V_{CB} = 10V, I_E = 0A, f = 1MHz$		40		pF
Turn-on Time	t_{ON}	See test circuit		100		ns
Storage Time	t_{STG}	See test circuit		900		ns
Fall Time	t_F	See test circuit		50		ns

■ CLASSIFICATION of h_{FE1}

RANK	R	S	T	Q
RANGE	100 - 200	140 - 280	200 - 400	70 - 140

■ TEST CIRCUIT

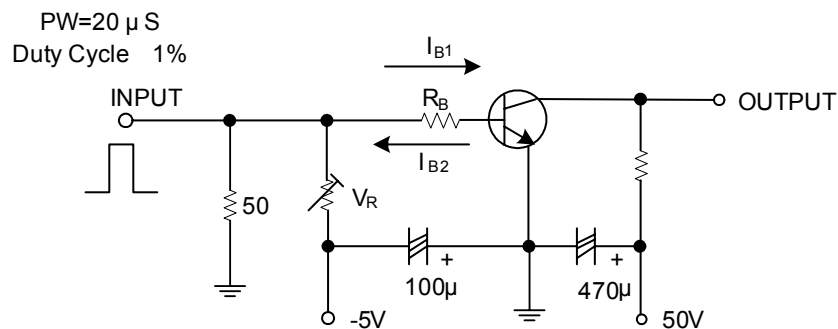

$I_C = 10, I_{B1} = -10, I_{B2} = 2A$
Unit (resistance: Ω , capacitance: F)

TYPICAL CHARACTERISTICS

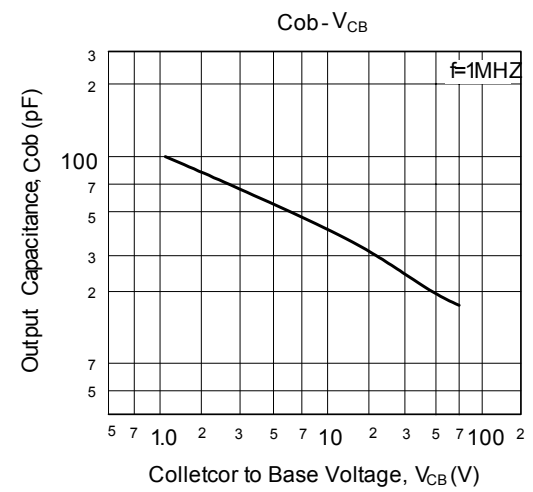
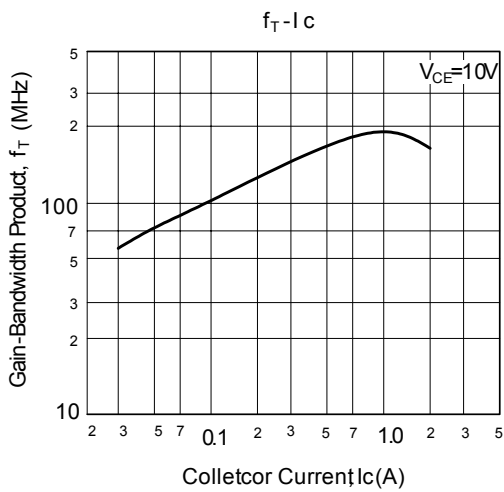
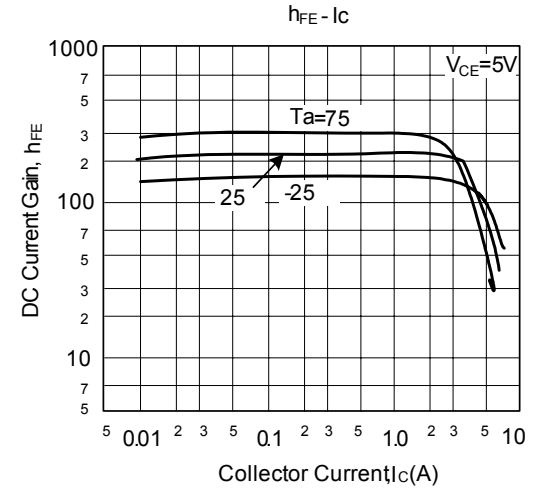
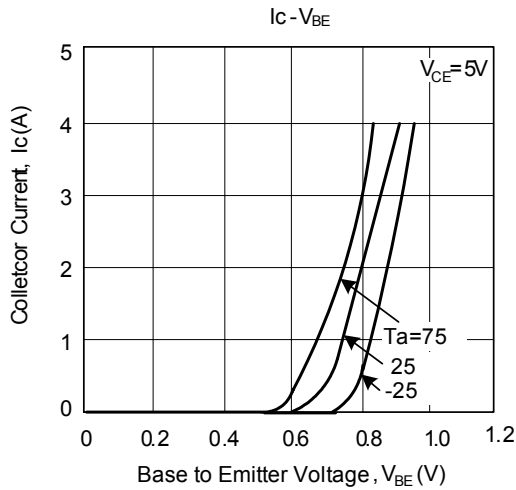
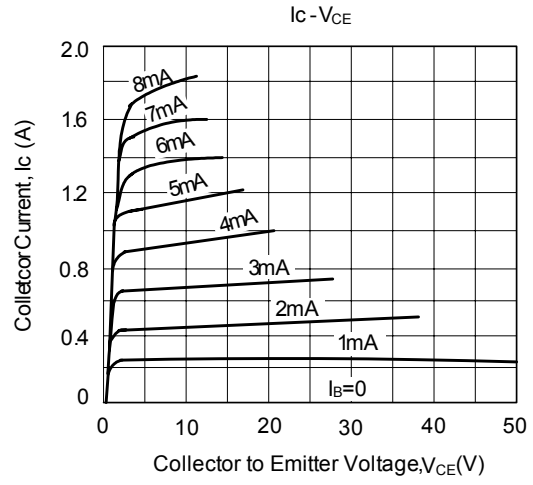
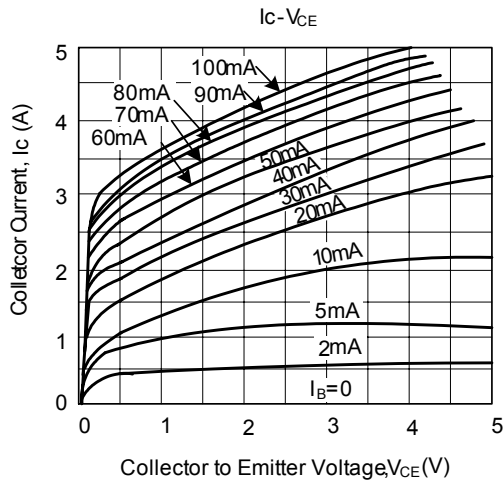

■ TYPICAL CHARACTERISTICS(Cont.)

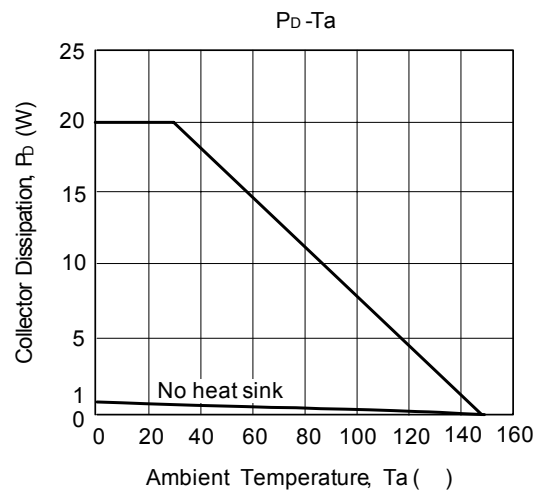
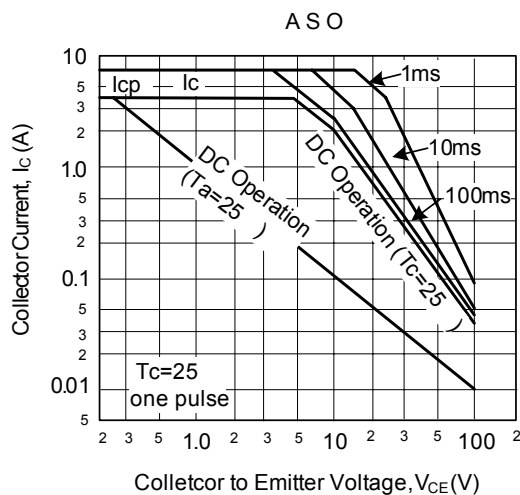
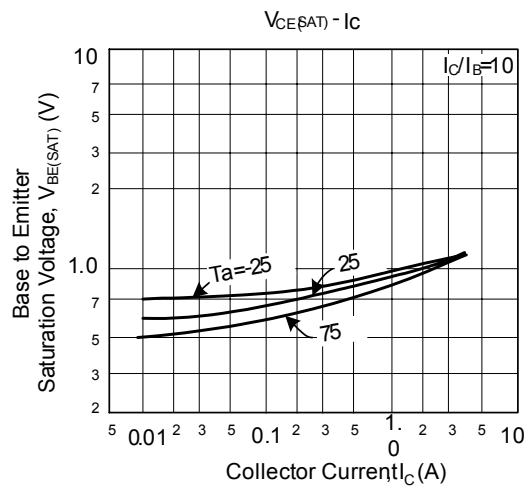
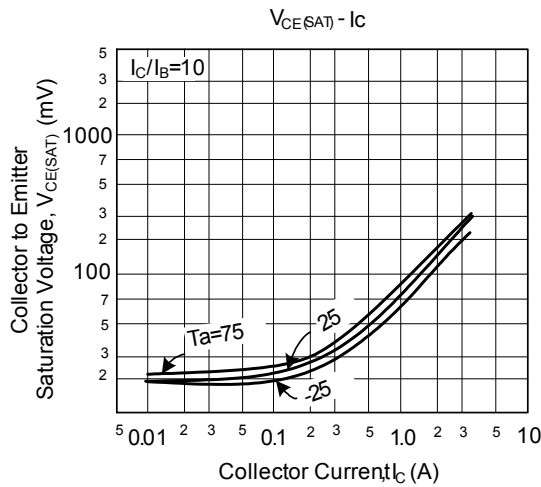

UTC assumes no responsibility for equipment failures that result from using products at values that exceed, even momentarily, rated values (such as maximum ratings, operating condition ranges, or other parameters) listed in products specifications of any and all UTC products described or contained herein. UTC products are not designed for use in life support appliances, devices or systems where malfunction of these products can be reasonably expected to result in personal injury. Reproduction in whole or in part is prohibited without the prior written consent of the copyright owner. The information presented in this document does not form part of any quotation or contract, is believed to be accurate and reliable and may be changed without notice.