



L13022

NPN SILICON TRANSISTOR

NPN TRIPLE DIFFUSED PLANAR TYPE HIGH VOLTAGE TRANSISTOR

DESCRIPTION

The UTC **L13022** is a medium power transistor designed for use in switching applications.

FEATURES

- * High breakdown voltage
- * Low collector saturation voltage
- * Fast switching speed

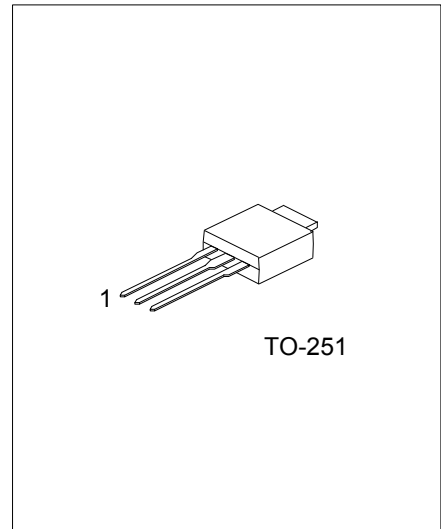

Lead-free: L13022L
Halogen-free : L13022G

ORDERING INFORMATION

Ordering Number			Package	Pin Assignment			Packing
Normal	Lead Free	Halogen Free		1	2	3	
L13022-TM3-T	L13022L-TM3-T	L13022G-TM3-T	TO-251	B	C	E	Tube

<p>L13022L-TM3-T</p>	<p>(1) Packing Type</p> <p>(2) Package Type</p> <p>(3) Lead Plating</p>	<p>(1) T: Tube</p> <p>(2) TM3: TO-251</p> <p>(3) G: Halogen Free, L: Lead Free, Blank: Pb/Sn</p>
----------------------	---	--

■ ABSOLUTE MAXIMUM RATING ($T_A=25^\circ\text{C}$)

PARAMETER		SYMBOL	RATINGS	UNIT
Collector-Base Voltage		V_{CBO}	600	V
Collector-Emitter Voltage		V_{CEO}	400	V
Emitter-Base Voltage		V_{EBO}	6	V
Collector Current	DC	I_C	800	mA
	Pulse		1600	
Base Current	DC	I_B	100	mA
	Pulse		200	
Total Power Dissipation ($T_C=25^\circ\text{C}$)		P_D	20	W
Junction Temperature		T_J	150	$^\circ\text{C}$
Storage Temperature		T_{STG}	-40 ~ +150	$^\circ\text{C}$

Note: Absolute maximum ratings are those values beyond which the device could be permanently damaged.
Absolute maximum ratings are stress ratings only and functional device operation is not implied.

■ ELECTRICAL CHARACTERISTICS ($T_A=25^\circ\text{C}$, unless otherwise specified.)

PARAMETER	SYMBOL	TEST CONDITIONS	MIN	TYP	MAX	UNIT
OFF CHARACTERISTICS						
Collector-Base Breakdown Voltage	BV_{CBO}	$I_C=100\mu\text{A}$	600			V
Collector-Emitter Breakdown Voltage	BV_{CEO}	$I_C=10\text{mA}$	400			V
Emitter-Base Breakdown Voltage	BV_{EBO}	$I_E=10\mu\text{A}$	6			V
Collector Cutoff Current	I_{CBO}	$V_{CB}=600\text{V}$			10	μA
Collector Cutoff Current	I_{CEO}	$V_{CB}=400\text{V}$			10	μA
Emitter Cutoff Current	I_{EBO}	$V_{EB}=6\text{V}$			10	μA
ON CHARACTERISTICS						
DC Current Gain(Note)	h_{FE1}	$V_{CE}=10\text{V}, I_C=0.1\text{A}$	10		40	
	h_{FE2}	$V_{CE}=10\text{V}, I_C=0.5\text{A}$	10			
Collector-Emitter Saturation Voltage (Note)	$V_{CE(SAT)}$	$I_C=100\text{mA}, I_B=20\text{mA}$			400	mV
		$I_C=300\text{mA}, I_B=60\text{mA}$			800	
Base-Emitter Saturation Voltage (Note)	$V_{BE(SAT)}$	$I_C=100\text{mA}, I_B=20\text{mA}$			1	V
SWITCHING CHARACTERISTICS						
Fall Time	t_F	$V_{CC}=100\text{V}, I_C=0.3\text{A},$ $I_{B1}=-I_{B2}=0.06\text{A}$			0.6	μS

Note: Pulse Test : Pulse Width $\leq 380\mu\text{s}$, Duty Cycle $\leq 2\%$

■ CLASSIFICATION OF h_{FE1}

RANK	B1	B2	B3	B4	B5	B6
Range	10 ~ 17	13 ~ 22	18 ~ 27	23 ~ 32	28 ~ 37	33 ~ 40

TYPICAL CHARACTERISTICS

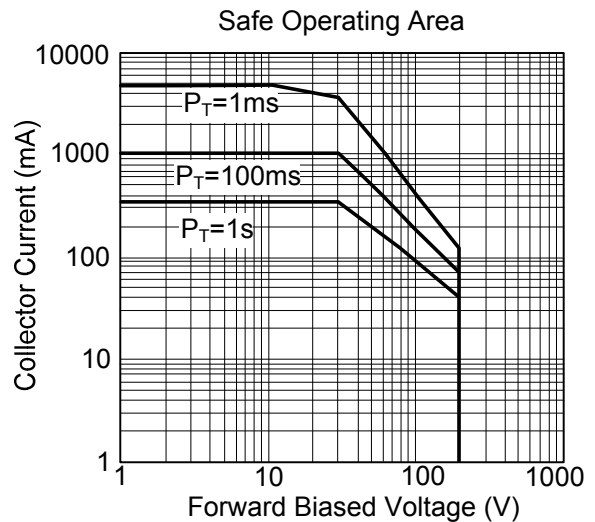
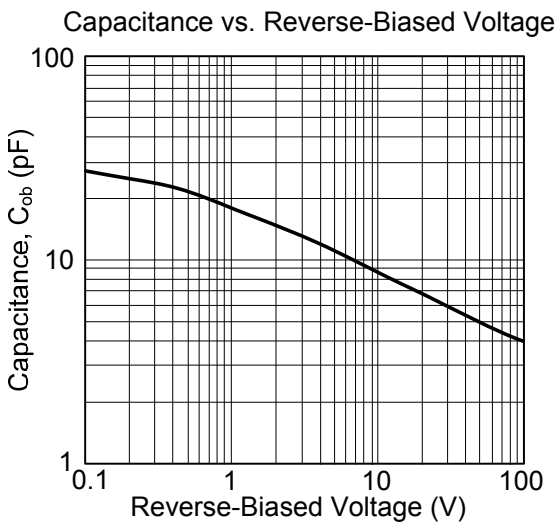
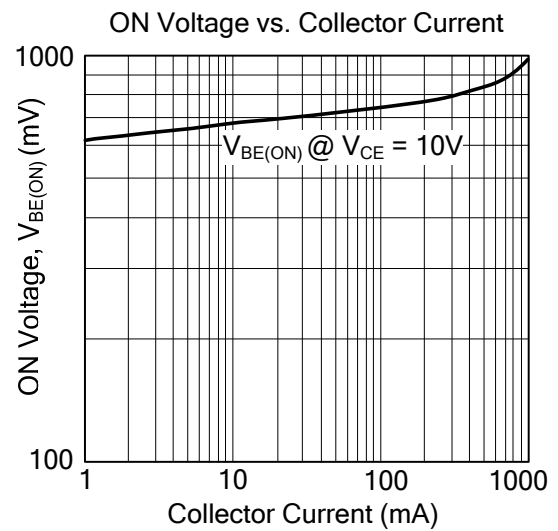
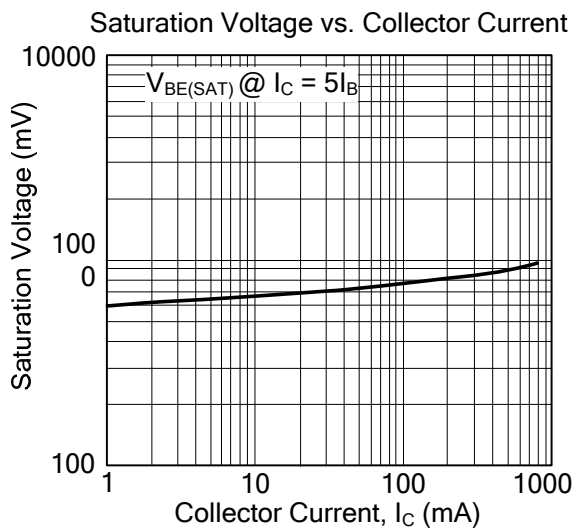
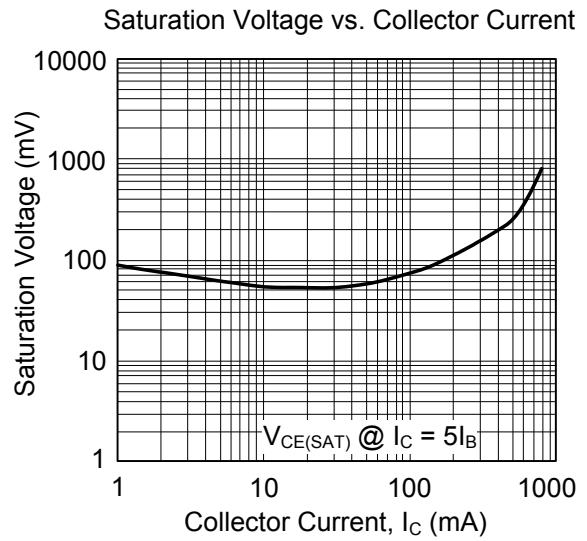
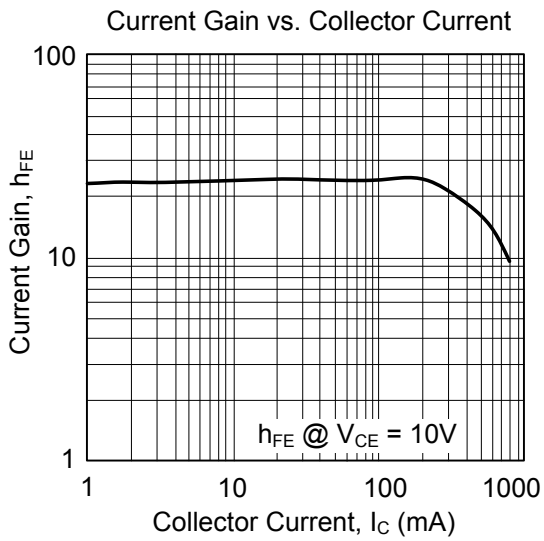

■ TYPICAL CHARACTERISTICS(Cont.)

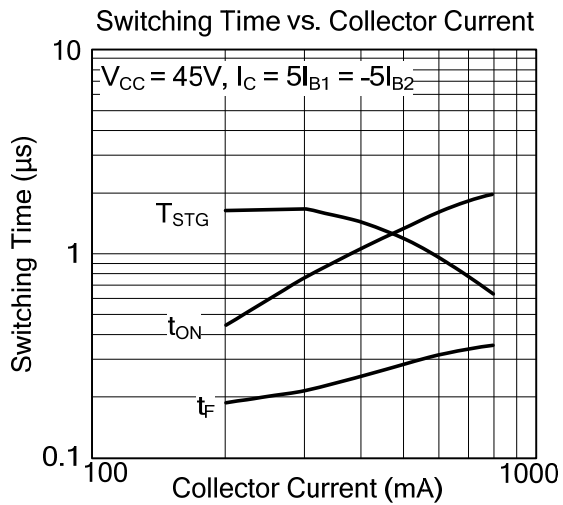

UTC assumes no responsibility for equipment failures that result from using products at values that exceed, even momentarily, rated values (such as maximum ratings, operating condition ranges, or other parameters) listed in products specifications of any and all UTC products described or contained herein. UTC products are not designed for use in life support appliances, devices or systems where malfunction of these products can be reasonably expected to result in personal injury. Reproduction in whole or in part is prohibited without the prior written consent of the copyright owner. The information presented in this document does not form part of any quotation or contract, is believed to be accurate and reliable and may be changed without notice.