



## L13024

## NPN SILICON TRANSISTOR

### NPN EPITAXIAL PLANAR TRANSISTOR

#### DESCRIPTION

The UTC **L13024** is designed for high voltage, high speed switching inductive circuits, and amplifier applications.

#### FEATURES

- \* High Speed Switching
- \* Low Saturation Voltage
- \* High Reliability

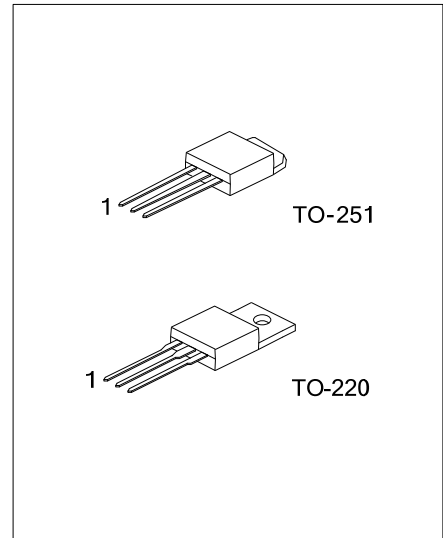

Lead-free: L13024L  
Halogen-free : L13024G

#### ORDERING INFORMATION

Ordering Number			Package	Pin Assignment			Packing
Normal	Lead Free	Halogen Free		1	2	3	
L13024-TA3-T	L13024L-TA3-T	L13024G-TA3-T	TO-220	B	C	E	Tube
L13024-TM3-T	L13024L-TM3-T	L13024G-TM3-T	TO-251	B	C	E	Tube

<p>L13024L-TA3-T</p> <p>(1)Packing Type</p> <p>(2)Package Type</p> <p>(3)Lead Plating</p>	<p>(1) T: Tube</p> <p>(2) TA3: TO-220, TM3: TO-251</p> <p>(3) G: Halogen Free, L: Lead Free, Blank: Pb/Sn</p>
---	---

■ ABSOLUTE MAXIMUM RATING ( $T_A=25^\circ\text{C}$ )

PARAMETER	SYMBOL	RATINGS	UNIT
Collector-Base Voltage	$V_{CBO}$	600	V
Collector-Emitter Voltage	$V_{CEO}$	400	V
Emitter-Base Voltage	$V_{EBO}$	8	V
Collector Current	DC	2	mA
	Pulse	4	
Base Current	DC	1	mA
	Pulse	2	
Total Power Dissipation ( $T_C=25^\circ\text{C}$ )	TO-220	35	W
	TO-251	20	
Junction Temperature	$T_J$	150	$^\circ\text{C}$
Storage Temperature	$T_{STG}$	-40 ~ +150	$^\circ\text{C}$

Note: Absolute maximum ratings are those values beyond which the device could be permanently damaged.  
Absolute maximum ratings are stress ratings only and functional device operation is not implied.

■ ELECTRICAL CHARACTERISTICS ( $T_A=25^\circ\text{C}$ , unless otherwise specified.)

PARAMETER	SYMBOL	TEST CONDITIONS	MIN	TYP	MAX	UNIT
<b>OFF CHARACTERISTICS</b>						
Collector-Base Breakdown Voltage	$BV_{CBO}$	$I_C=1\text{mA}$	600			V
Collector-Emitter Breakdown Voltage	$BV_{CEO}$	$I_C=10\text{mA}$	400			V
Emitter-Base Breakdown Voltage	$BV_{EBO}$	$I_E=1\text{mA}$	8			V
Collector Cutoff Current	$I_{CBO}$	$V_{CB}=600\text{V}$			10	$\mu\text{A}$
Emitter Cutoff Current	$I_{EBO}$	$V_{EB}=9\text{V}, I_C=0$			10	$\mu\text{A}$
<b>ON CHARACTERISTICS</b>						
DC Current Gain(Note)	$h_{FE1}$	$V_{CE}=5\text{V}, I_C=0.3\text{A}$	10		40	
	$h_{FE2}$	$V_{CE}=5\text{V}, I_C=0.5\text{A}$	10			
	$h_{FE3}$	$V_{CE}=5\text{V}, I_C=1\text{A}$	6			
Collector-Emitter Saturation Voltage (Note)	$V_{CE(SAT)}$	$I_C=0.1\text{A}, I_B=10\text{mA}$			0.3	V
		$I_C=0.3\text{A}, I_B=30\text{mA}$			0.8	
Base-Emitter Saturation Voltage (Note)	$V_{BE(SAT)}$	$I_C=0.1\text{A}, I_B=10\text{mA}$			0.9	V
		$I_C=0.3\text{A}, I_B=30\text{mA}$			1.2	
<b>SWITCHING CHARACTERISTICS</b>						
Gain-Bandwidth Product	$f_T$	$V_{CE}=10\text{V}, I_C=0.3\text{A}, f=1\text{MHz}$	15			MHz

Note: Pulse Test : Pulse Width  $\leq 380\mu\text{s}$ , Duty Cycle  $\leq 2\%$

■ CLASSIFICATION OF  $h_{FE1}$

RANK	B1	B2	B3	B4	B5	B6
Range	10 ~ 17	13 ~ 22	18 ~ 27	23 ~ 32	28 ~ 37	33 ~ 40

### TYPICAL CHARACTERISTICS

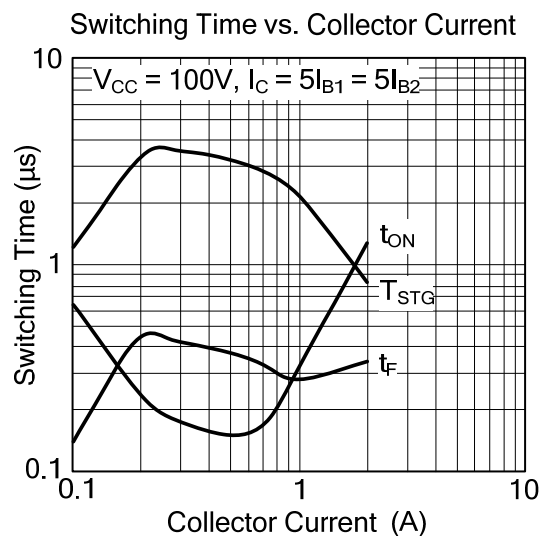
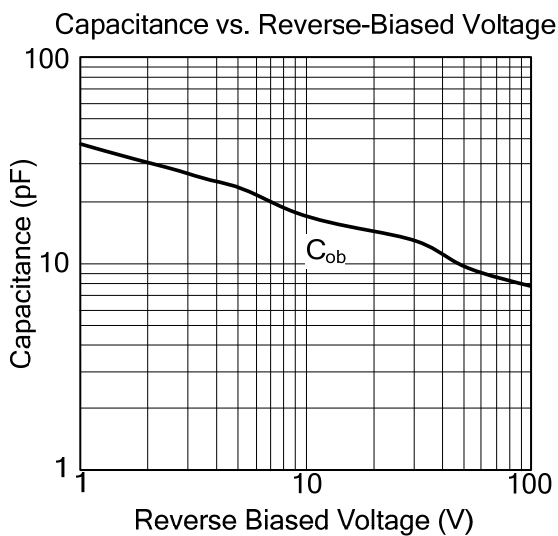
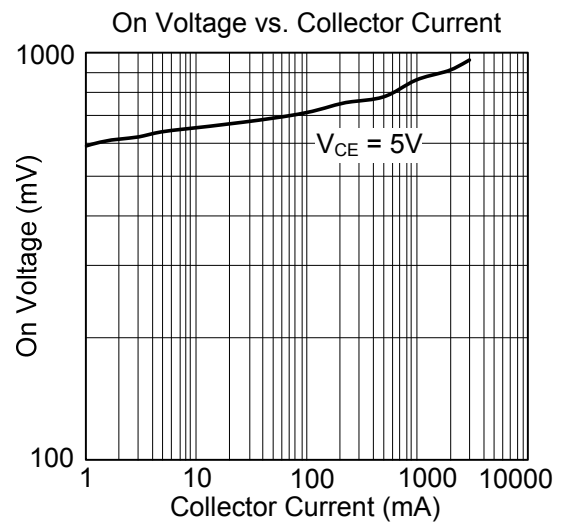
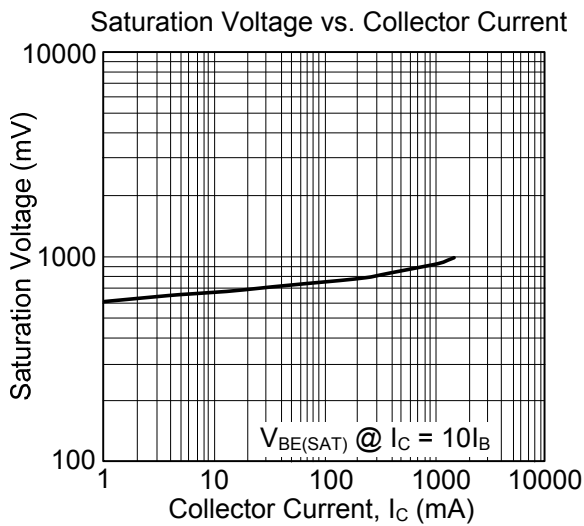
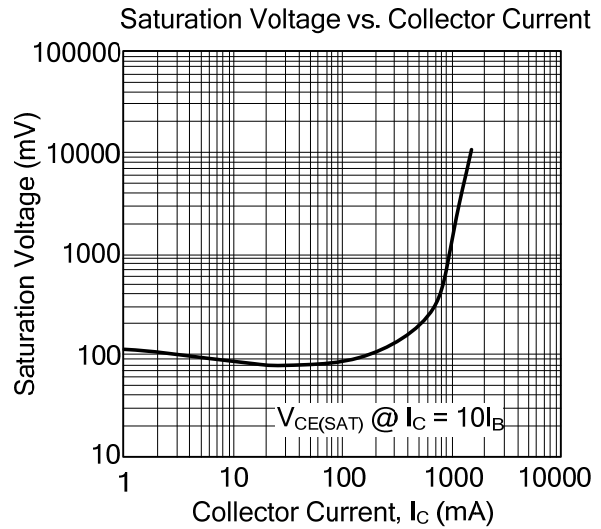
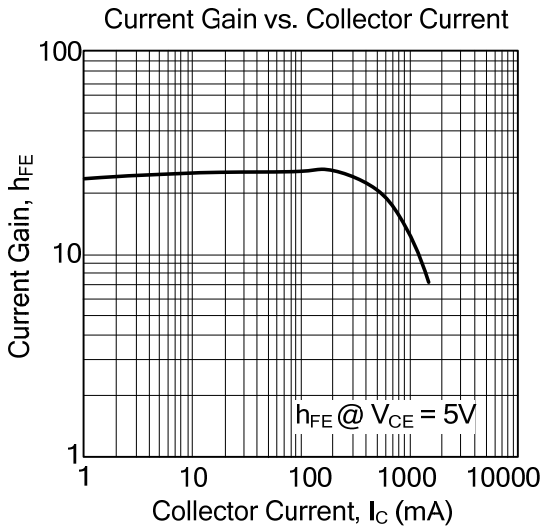

### ■ TYPICAL CHARACTERISTICS(Cont.)

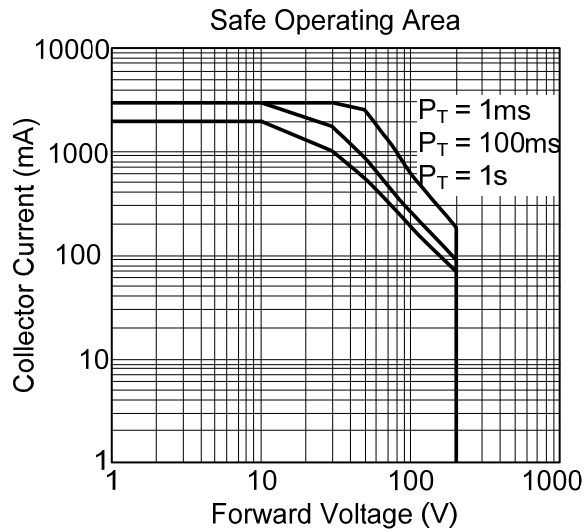

UTC assumes no responsibility for equipment failures that result from using products at values that exceed, even momentarily, rated values (such as maximum ratings, operating condition ranges, or other parameters) listed in products specifications of any and all UTC products described or contained herein. UTC products are not designed for use in life support appliances, devices or systems where malfunction of these products can be reasonably expected to result in personal injury. Reproduction in whole or in part is prohibited without the prior written consent of the copyright owner. The information presented in this document does not form part of any quotation or contract, is believed to be accurate and reliable and may be changed without notice.