



## L2044

### LINEAR INTEGRATED CIRCUIT

## DUAL OUTPUT FLASHER

### DESCRIPTION

The UTC **L2044** is a dual output stages flasher designed as a relay driver for flashing light control in automotive applications. Both sides direction indicator input with only a small control current makes switch contacts for small loads possible. Each side of the vehicle is controlled separately.

The construction of the hazard switch could be simplified due to hazard warning input is separate. The flasher will dramatically increase the flash frequency by a typical ratio of 2:1 if lamp fault is detected. The UTC **L2044** can be directly connected to the battery due to extreme low current consumption

### FEATURES

- \* Temperature and Supply Voltage Compensated Flashing Frequency
- \* Frequency Doubling Indicates Lamp Fault.
- \* Two Relay Driver Outputs with High Current-carrying Capacity and Low Saturation Voltage
- \* Minimum Lamp Load for Flasher Operation:  $\geq 1W$
- \* Very Low Sensitivity to EMI
- \* Extremely Low Current Consumption  $< 10\mu A$  ( at Switches Open)
- \* Reverse Polarity Protection
- \* Three Control Inputs: Left, Right and Hazard Warning

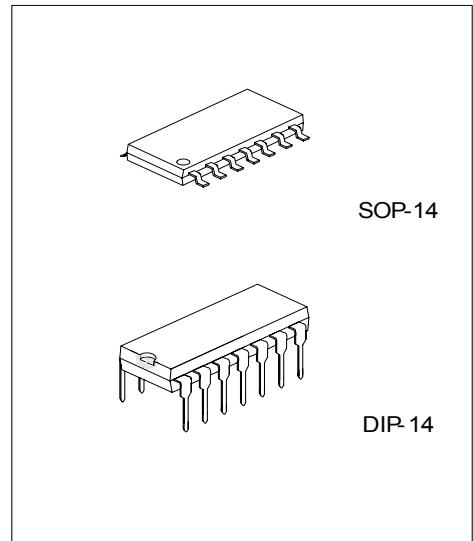

\*Pb-free plating product number: L2044L

### PIN DESCRIPTION

PIN No.	PIN NAME	FUNCTION
1	OSC	Oscillator
2	SIL	Start input left
3	SIR	Start input right
4	SIHW	Start input hazard warning
5	VS	V <sub>CC</sub>
6	CR1	Control input relay 1
7	CR2	Control input relay 2
8	LD	Lamp failure detection
9	VS	V <sub>CC</sub>
10	GND	ground
11	OR1	Output relay 1
12	VS	V <sub>CC</sub>
13	OR2	Output relay 2
14	OSC	Oscillator

### ORDERING INFORMATION

Order Number		Package	Packing
Normal	Lead free		
L2044-D14-T	L2044L-D14-T	DIP-14	Tube
L2044-S14-R	L2044L-S14-R	SOP-14	Tape Reel
L2044-S14-T	L2044L-S14-T	SOP-14	Tube

## ■ PIN CONFIGURATION

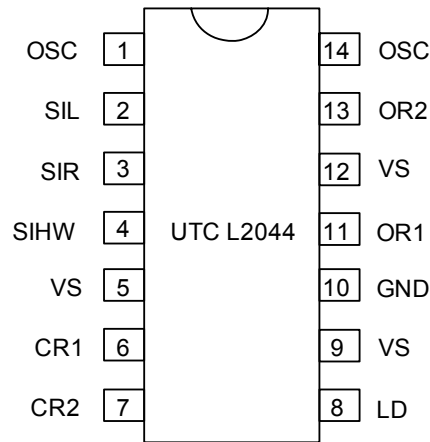

## ■ BLOCK DIAGRAM

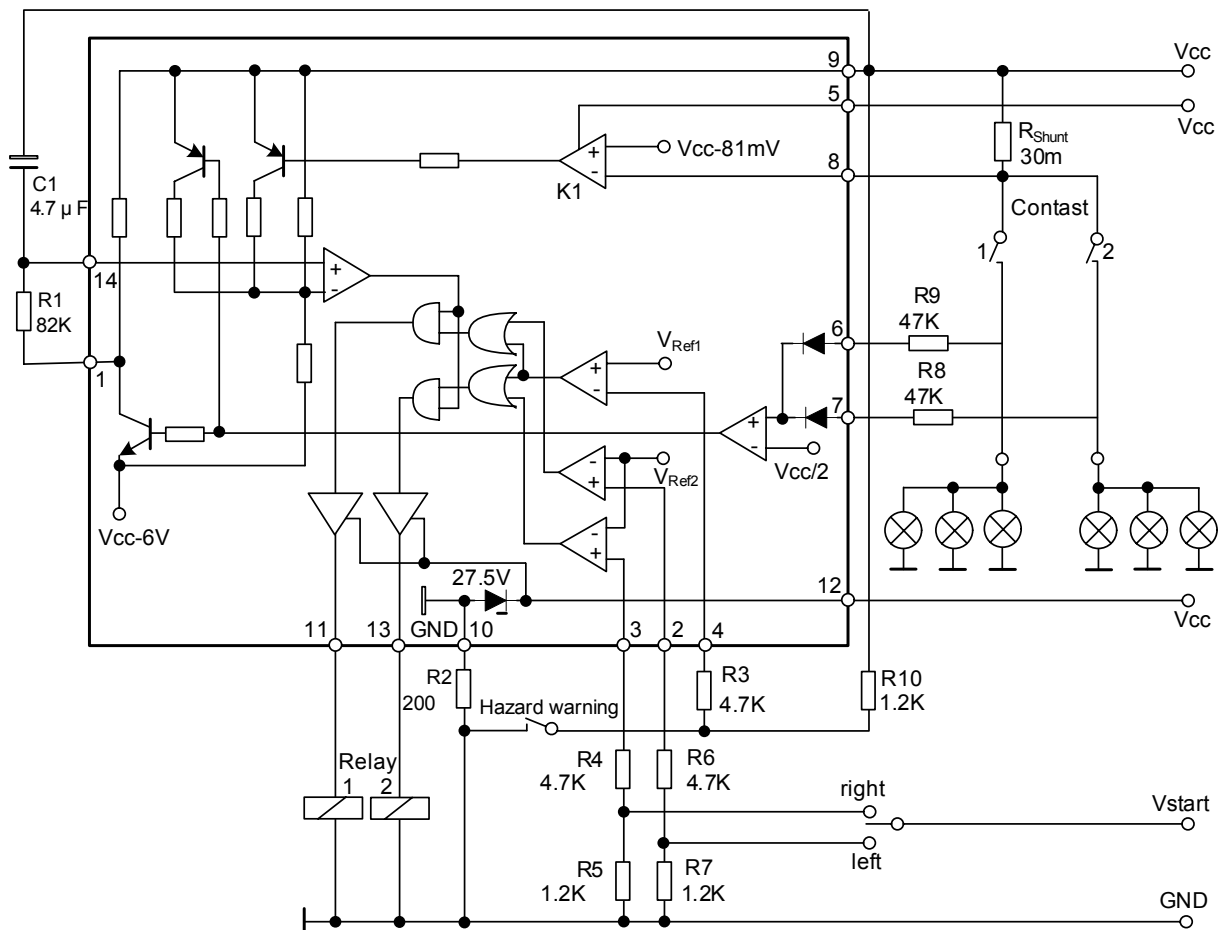

### ■ ABSOLUTE MAXIMUM RATINGS

PARAMETER	SYMBOL	RATINGS	UNIT
Supply Voltage, 1 min, pins 5, 9 and 12	$V_{CC}$	24	V
Junction Temperature	$T_J$	+125	
Operating Temperature	$T_{OPR}$	0 ~70	
Storage Temperature	$T_{STG}$	-40 ~ +150	
Thermal Resistance Junction to Ambient	DIP-14	90	/W
	SOP-14	120	

Note 1. Absolute maximum ratings are those values beyond which the device could be permanently damaged.

Absolute maximum ratings are stress ratings only and functional device operation is not implied.

2. The device is guaranteed to meet performance specification within 0 ~70 operating temperature range and assured by design from -20 ~85 .

### ■ ELECTRICAL CHARACTERISTICS ( $V_{CC} = 12V$ , $T_a = 25$ , unless otherwise specified.)

PARAMETER	SYMBOL	TEST CONDITIONS	MIN	TYP	MAX	UNIT
Supply Voltage Range	$V_{CC}$	Pins 5, 9, 12	8		18	V
Saturation Voltage	$V_{OUT}$	$R_L = 82\Omega$			1.0	V
					$V_{CC} = 12V$	
Clamping Voltage	$V_{12}$	$T_a = -20 \sim 85$	25.0	27.5	30.0	V
Relay output overvoltage detection (relay disabled)	$V_{12}$	$T_a = -20 \sim 85$	18	20	22	V
Control signal threshold	$V_{CC}$	$V_{CC} = 9V$ $V_{CC} = 13.5V$ $V_{CC} = 16V$		70.6 85.5 93.0		mV
Output current for relay driver	$I_{OUT}$	Pins 11, 13			300	mA
Relay output reverse current	$I_{OUT}$	Pins 11, 13			0.1	mA
Supply current, switches open	$I_{CC}$	Pins 5, 9, 12			10	$\mu A$
Relay coil resistance	$R_L$					$\Omega$
Start delay	$t_{ON}$	First bright phase			10	ms
Tolerance of control signal threshold		$V_{CC} = 9V \sim 16V$ , Pin 8, $T_a = -20 \sim 85$	-6		+6	%
Temperature coefficient of control signal Threshold	$T_C V_O$	$V_{CC} = 13.5V$ , Pin 8		10		$\mu V/K$

### ■ TOLERANCES ( $V_{CC} = 12V$ , $T_a = 25$ , unless otherwise specified.)

PARAMETER	SYMBOL	TEST CONDITIONS	MIN	TYP	MAX	UNIT
Frequency determining resistor	$R_1$		6.8		510	k $\Omega$
Frequency determining capacitor	$C_1$				47	$\mu F$
Frequency tolerance	$f_1$	Normal flashing, basic frequency $f_1$ excluding the tolerance of $R_1$ and $C_1$	-5		+5	%
Bright period	$f_1$	Basic frequency $f_1$	47		53	%
	$f_2$	Control frequency $f_2$	37		45	
Frequency increase	$f_2$	Lamp failure	$2.15 \times f_1$		$2.3 \times f_1$	Hz
Lamp load	$P_L$		1			W

UTC assumes no responsibility for equipment failures that result from using products at values that exceed, even momentarily, rated values (such as maximum ratings, operating condition ranges, or other parameters) listed in products specifications of any and all UTC products described or contained herein. UTC products are not designed for use in life support appliances, devices or systems where malfunction of these products can be reasonably expected to result in personal injury. Reproduction in whole or in part is prohibited without the prior written consent of the copyright owner. The information presented in this document does not form part of any quotation or contract, is believed to be accurate and reliable and may be changed without notice.