

# UTC L2800 LINEAR INTEGRATED CIRCUIT

## SWITCHING REGULATOR CONTROLLER (LOW VOLTAGE)

### DESCRIPTION

The UTC L2800 is a single-channel switching regulator control IC for low voltage applications incorporating a soft start function and short circuit detection function. The device has a low minimum operating voltage of 1.8V and is ideal for the power supply of battery-operated electronic equipment.

### FEATURES

- \*Wide supply voltage operating range: 1.8V~15V
- \*Low current consumption: Typically 5.5mA in operation, 1μA or less in stand-by
- \*High speed operation is possible: Maximum 1MHz
- \*The error amplifier gain is set inside the IC, so peripheral components are minimized.
- \*Incorporates a soft start circuit.
- \*Incorporates a timer-latch type short circuit detection circuit (SCP).
- \*Totem-pole type output with adjustable on/off current (for NPN transistors)
- \*Incorporates a stand-by function.

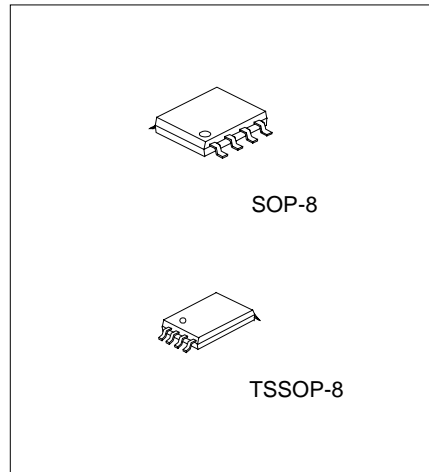

\*Pb-free plating product number: L2800L

### PIN CONFIGURATION

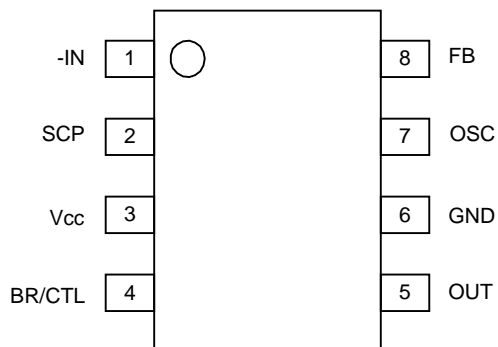

# UTC L2800 LINEAR INTEGRATED CIRCUIT

## PIN DESCRIPTION

PIN NO.	SYMBOL	I/O	DESCRIPTION
1	-IN	I	Error amplifier inverting input pin
2	SCP	-	Soft start and SCP setting capacitor connection pin
3	VCC	-	Power supply pin
4	BR/CTL	I	Output current setting and control pin
5	OUT	O	Totem-pole type output pin
6	GND	-	Ground pin
7	OSC	-	Capacitor and resistor connection pin for setting the oscillation frequency
8	FB	O	Error amplifier output pin

## BLOCK DIAGRAM

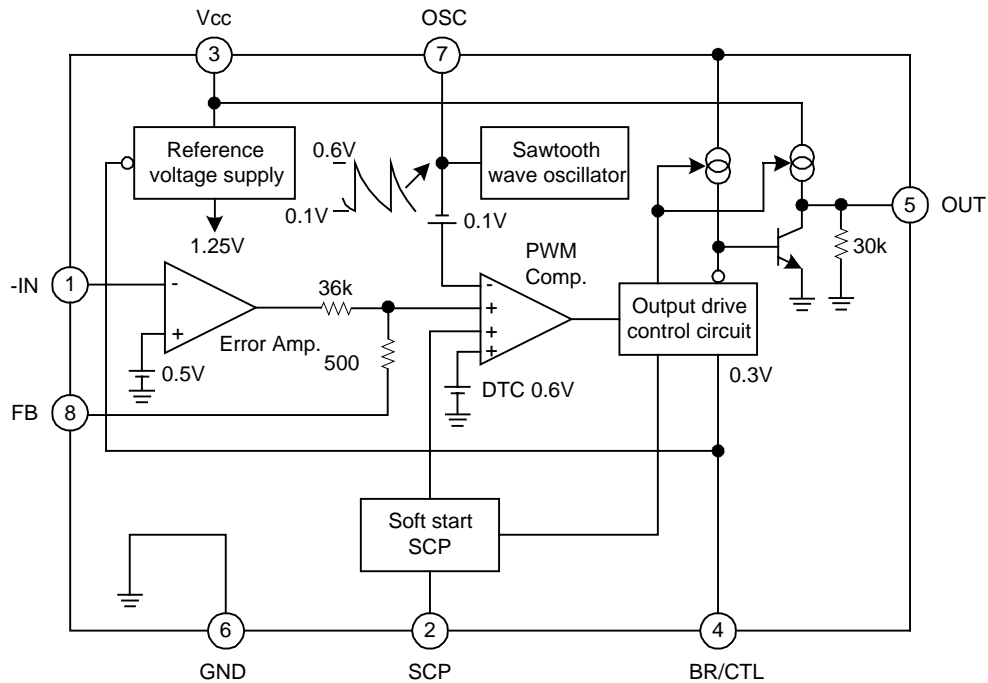

## ABSOLUTE MAXIMUM RATINGS (Ta=25°C)

PARAMETER	SYMBOL	RATINGS	UNIT
Power Supply Voltage	Vcc	16	V
Output Source Current	Io <sup>+</sup>	-50	mA
Output Sink Current	Io <sup>-</sup>	50	mA
Power Dissipation	P <sub>D</sub>	570* 580*	mW
Storage Temperature	T <sub>stg</sub>	-55 ~ +125	°C
Operating Temperature	T <sub>op</sub>	-30 ~ +85	°C

\* When mounted on a 10cm square double-sided epoxy board.

# UTC

UNISONIC TECHNOLOGIES CO., LTD.

2

QW-R103-030,A

# UTC L2800 LINEAR INTEGRATED CIRCUIT

## RECOMMENDED OPERATING CONDITIONS (Ta=25°C)

PARAMETER	SYMBOL	MIN	TYP	MAX	UNIT
Power Supply Voltage	V <sub>CC</sub>	1.8		15	V
Error Amplifier Input Voltage	V <sub>I</sub>	-0.2		1.0	V
BR/CTL Pin Input Voltage	V <sub>BR</sub>	-0.2		V <sub>CC</sub>	V
Output Source Current	I <sub>O</sub> <sup>+</sup>	-40			mA
Output Sink Current	I <sub>O</sub> <sup>-</sup>			40	mA
SCP Pin Capacitance	C <sub>PE</sub>		0.1		μF
Phase Compensation Capacitance	C <sub>P</sub>		0.1		μF
Output Current Setting Resistance	R <sub>B</sub>	150	390	5000	Ω
Timing Resistance	R <sub>T</sub>	1.0	3.0	10.0	kΩ
Timing Capacitance	C <sub>T</sub>	100	270	10000	pF
Oscillation Frequency	f <sub>OSC</sub>	10	500	1000	kHz
Operating Temperature	T <sub>OP</sub>	-30	+25	+85	°C

## ELECTRICAL CHARACTERISTICS (Ta=25°C, V<sub>CC</sub>=+2V)

PARAMETER		SYMBOL	TEST CONDITIONS	MIN	TYP	MAX	UNIT
Circuit to prevent malfunction at low input voltage (U.V.L.O)	Reset Voltage	V <sub>R</sub>				0.9	V
	Threshold Voltage	V <sub>TH</sub>		1.1	1.3	1.5	V
Soft Start	Charging Current	I <sub>CS</sub>	V <sub>SCP</sub> =0V	-1.5	-1.0	-0.7	μA
	Voltage at soft start completion	V <sub>TS</sub>		0.7	0.8	0.9	V
Short Circuit Detection(S.C.P.)	Charging Current	I <sub>CP</sub>	V <sub>SCP</sub> =0V	-1.5	-1.0	-0.7	μA
	Threshold Voltage	V <sub>TP</sub>		0.7	0.8	0.9	V
Sawtooth Wave Oscillator(OSC)	Oscillation Frequency	f <sub>OSC</sub>	R <sub>T</sub> =3.0kΩ, C <sub>T</sub> =270pF	400	500	600	kHz
	Frequency Input Stability	f <sub>dV</sub>	V <sub>CC</sub> =2V ~ 15V		2	10	%
	Frequency Variation With Temperature	f <sub>dT</sub>	Ta=-30°C ~ +85°C		5		%
Error Amplifier	Input Threshold Voltage	V <sub>T</sub>	V <sub>FB</sub> =450mV	480	500	520	mV
	V <sub>T</sub> Input Stability	V <sub>TdV</sub>	V <sub>CC</sub> =2V ~ 15V		5	20	mV
	V <sub>T</sub> Variation With Temperature	V <sub>TdT</sub>	Ta=-30°C ~ +85°C		1		%
	Input Bias Current	I <sub>B</sub>	V <sub>IN</sub> =0V	-1.0	-0.2	1.0	μA
	Voltage Gain	A <sub>V</sub>		70	100	145	V/V
	Frequency Bandwidth	BW	A <sub>V</sub> =0dB		6		MHz
	Maximum Output Voltage Range	V <sub>OM</sub> <sup>+</sup> V <sub>OM</sub> <sup>-</sup>		0.78	0.87		V
	Output Source Current Output Sink Current	I <sub>OM</sub> <sup>+</sup> I <sub>OM</sub> <sup>-</sup>	V <sub>FB</sub> =0.45V		-40	-24	μA
Idle Period Adjustment Section	Maximum Duty Cycle	t <sub>DUTY</sub>	R <sub>T</sub> =3.0kΩ, C <sub>T</sub> =270pF V <sub>FB</sub> =0.8V	65	75	85	%
Output Section	Output Voltage	V <sub>OH1</sub>	R <sub>B</sub> =390Ω, I <sub>O</sub> =-15mA	1.0	1.2		V
		V <sub>OH2</sub>	R <sub>B</sub> =750Ω, V <sub>CC</sub> =1.8V I <sub>O</sub> =-10mA	0.8	1.0		V
		V <sub>OL1</sub>	R <sub>B</sub> =390Ω, I <sub>O</sub> =15mA		0.1	0.2	V
		V <sub>OL2</sub>	R <sub>B</sub> =750Ω, V <sub>CC</sub> =1.8V I <sub>O</sub> =10mA		0.1	0.2	V
	Output Source Current	I <sub>O</sub> <sup>+</sup>	R <sub>B</sub> =390Ω, V <sub>O</sub> =0.9V		-30	-20	mA
	Output Sink Current	I <sub>O</sub> <sup>-</sup>	R <sub>B</sub> =390Ω, V <sub>O</sub> =0.3V	30	60		mA
Pull Down Resistance	R <sub>O</sub>		20	30	40	kΩ	

# UTC L2800 LINEAR INTEGRATED CIRCUIT

PARAMETER		SYMBOL	TEST CONDITIONS	MIN	TYP	MAX	UNIT
Output Current Setting Section/Control Section	Pin Voltage	VBR	R <sub>B</sub> =390Ω	0.2	0.3	0.4	V
	Input Off Condition	I <sub>OFF</sub>		-20		0	μA
	Input On Condition	I <sub>ON</sub>				-45	μA
	Pin Current Range	I <sub>BR</sub>		-1.8		-0.1	mA
Entire Device	Stand-by Current	I <sub>CCS</sub>	BR/CTL pin open or V <sub>CC</sub>			1	μA
	Average Supply Current	I <sub>CC</sub>	R <sub>B</sub> =390Ω		5.5	9.3	mA

## DIAGRAM

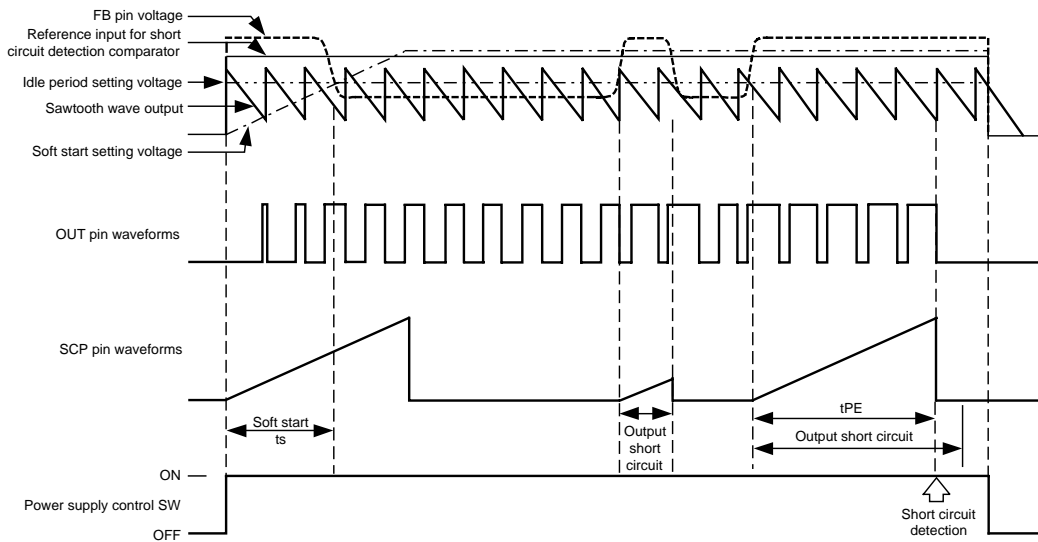

## HOW TO SET THE TIME CONSTANT FOR SOFT START AND SHORT CIRCUIT DETECTION

### 1.SOFT START

At power on, the capacitor C<sub>PE</sub> connected to the SCP pin starts charging. The PWM comparator compares the soft start setting voltage as a proportion of the voltage at the SCP pin with the sawtooth waveform. The comparison controls the ON duty of the OUT pin, causing the soft start operation. On completion of soft start operation, the voltage at the SCP pin stays low, the soft start setting voltage stays high, and the circuit enters the output short circuit detection wait state.

Soft start time (The time until the output ON duty reaches approximately 50%)

$$t_s[S] \approx 0.35 \cdot C_{PE}[\mu F]$$

### 2.SHORT CIRCUIT PROTECTION

If the switching regulator output suddenly drops due to load effect, the error amplifier output (FB pin) is fixed at V<sub>OM</sub><sup>+</sup> and capacitor C<sub>PE</sub> starts charging. When the voltage at the SCP pin reaches approximately 0.8V, the output pin is set low and the SCP pin stays low.

Once the protection circuit operates, the circuit can be restored by resetting the power supply.

- Short circuit detection time

$$t_{PE}[S] \approx 0.8 \cdot C_{PE}[\mu F]$$

# UTC L2800 LINEAR INTEGRATED CIRCUIT

## TYPICAL CHARACTERISTICS

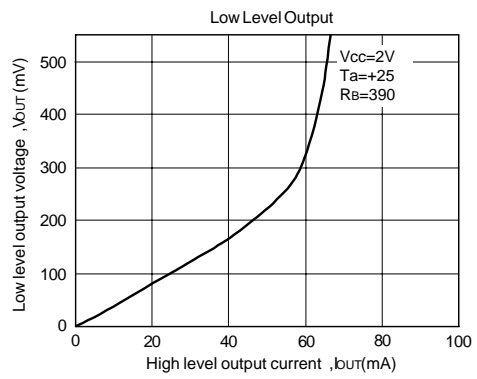
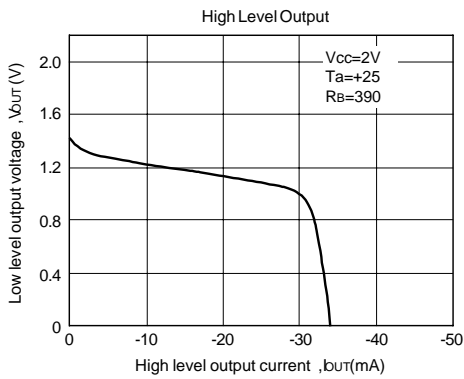
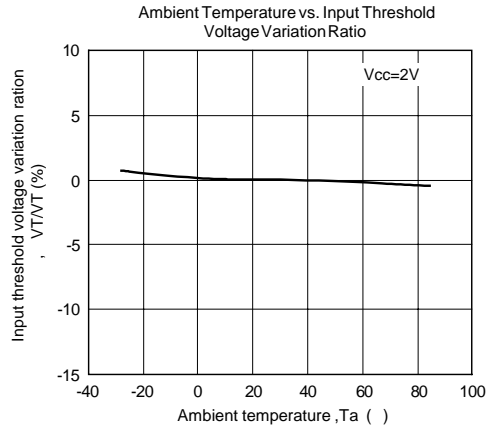
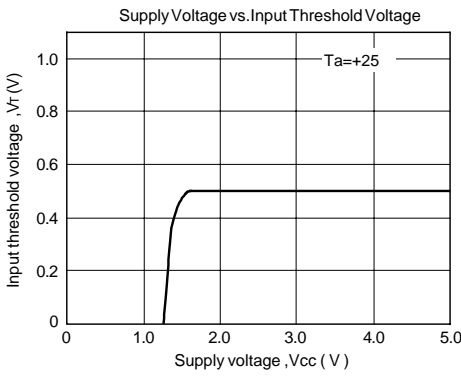
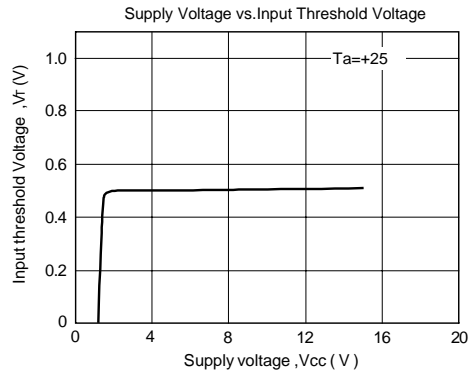
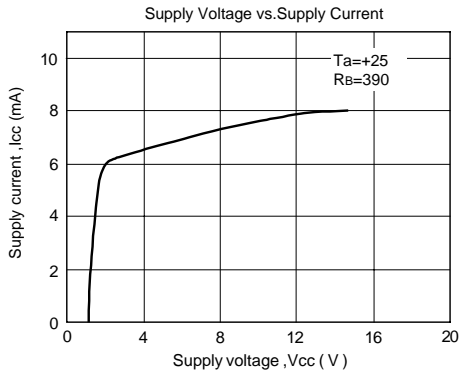

# UTC L2800 LINEAR INTEGRATED CIRCUIT

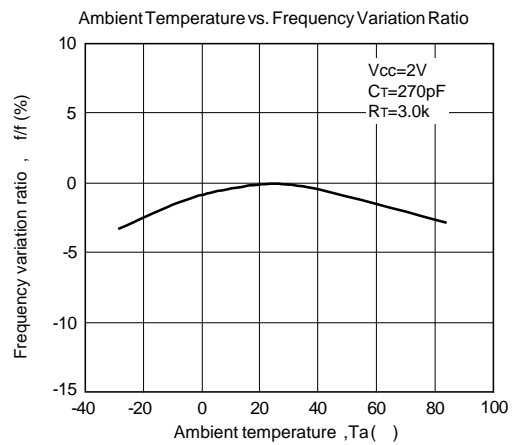
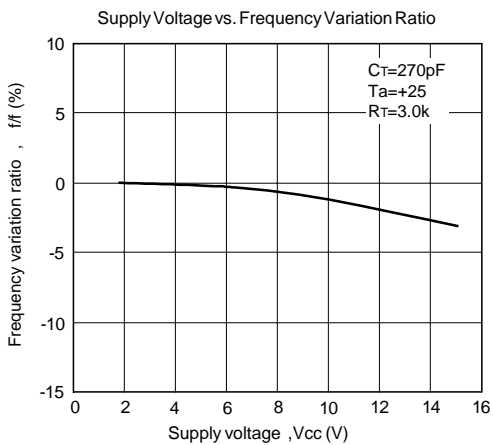
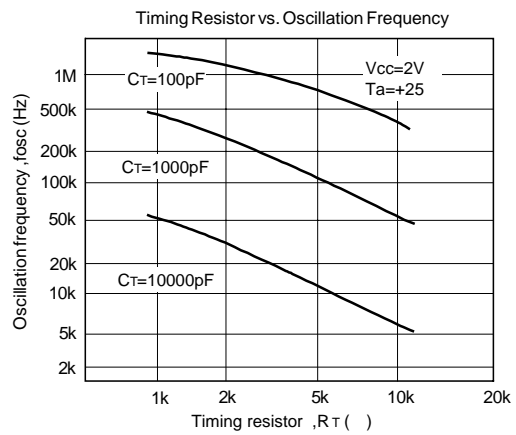
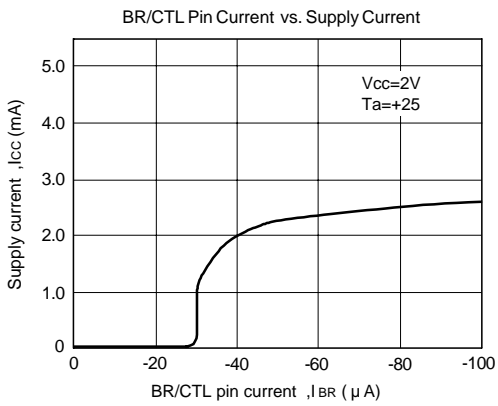
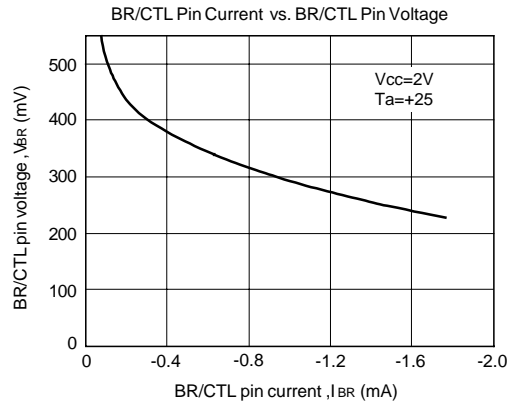
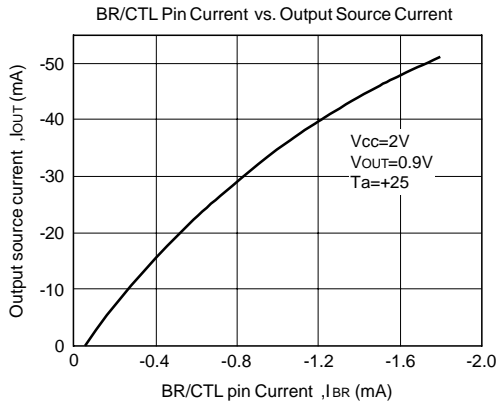

# UTC L2800 LINEAR INTEGRATED CIRCUIT

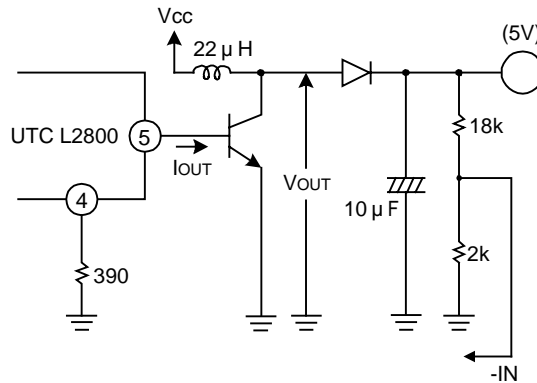
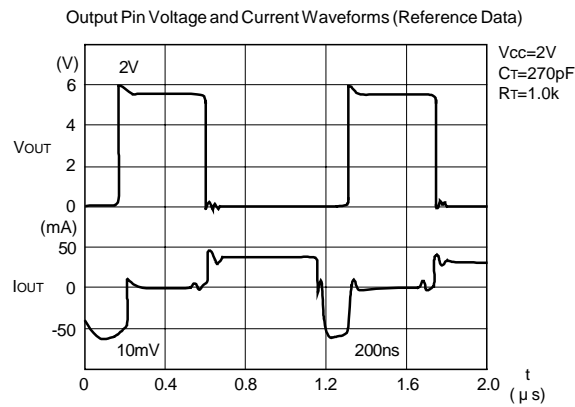
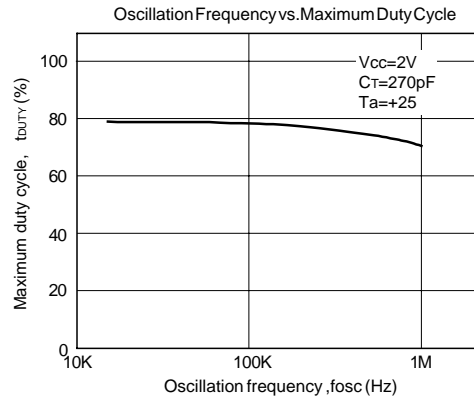

# UTC L2800 LINEAR INTEGRATED CIRCUIT

## FUNCTIONAL DESCRIPTION

### 1. SWITCHING REGULATOR FUNCTION

#### (1) REFERENCE VOLTAGE CIRCUIT

The reference voltage circuit generates a temperature-compensated reference voltage(= 1.25V)from voltage supplied from the power supply pin(pin 30).In addition to providing the reference voltage for the switching regulator, the circuit also sets the idle period.

#### (2) SAWTOOTH WAVE OSCILLATOR

The sawtooth oscillator generates a sawtooth wave(up to 1 MHz)that is stable with respect to the supply voltage and temperature. The capacitor and resistor that set the oscillation frequency are connected to the OSC pin(pin 7).

#### (3) ERROR AMPLIFIER (ERROR AMP.)

The error amplifier detects the output voltage of the switching regulator and outputs the PWM control signal. The voltage gain is fixed, and connecting a phase compensation capacitor to the FB pin(pin 8)provides stable phase compensation for the system.

#### (4) PWM COMPARATOR (PWM COMP.)

The voltage comparator has one inverting and three non-inverting inputs. The comparator is a voltage /pulse width converter that controls the ON time of the output pulse depending on the input voltage. The output level is high(H) when the sawtooth wave is lower than the error amplifier output voltage, soft start setting voltage, and idle period setting voltage.

#### (5) OUTPUT CIRCUIT

The output circuit has a totem pole type configuration and can drive an external NPN transistor directly. The value of the ON/OFF current can be set by a resistor connected to the BR/CTL pin(pin 4).

### 2. POWER SUPPLY CONTROL FUNCTION

Stand-by mode(supply current 1 $\mu$ A or less) can be set by connecting the BR/CTL pin(pin 4) to Vcc or by making the pin open circuit.

SW	MODE
OFF	Stand-by mode
ON	Operating mode

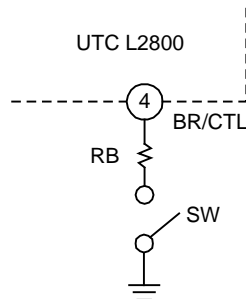

### 3. OTHER FUNCTIONS

#### (1) SOFT START AND SHORT CIRCUIT DETECTION

Soft start operation is set by connecting capacitor C<sub>PE</sub> to SCP pin(pin 2).Soft start prevents a current spike on start-up.

On completion of soft start operation, the SCP pin(pin 2) stays low and enters the short circuit detection wait state. When an output short circuit occurs, the error amplifier output is fixed at V<sub>OM+</sub> and capacitor C<sub>PE</sub> starts charging. After charging to approximately 0.8V, the output pin(pin 5) is set low and the SCP pin(pin 2) stays low.

Once the protection circuit operates, the circuit can be restored by resetting the power supply.(See "HOW TO SET THE TIME CONSTANT FOR SOFT START AND SHORT CIRCUIT DETECTION")

# UTC L2800 LINEAR INTEGRATED CIRCUIT

## (2) CIRCUIT TO PREVENT MALFUNCTION AT LOW INPUT VOLTAGE

Transients when powering on or instantaneous glitches in the supply voltage can lead to malfunction of the control IC and cause system damage or failure. The circuit to prevent malfunction at low input voltage detects a low input voltage by comparing the supply voltage to the internal reference voltage. On detection, the circuit fixes the output pin to low.

The system recovers when the supply voltage rises back above the threshold voltage of the malfunction prevention circuit.

## APPLICATION EXAMPLE

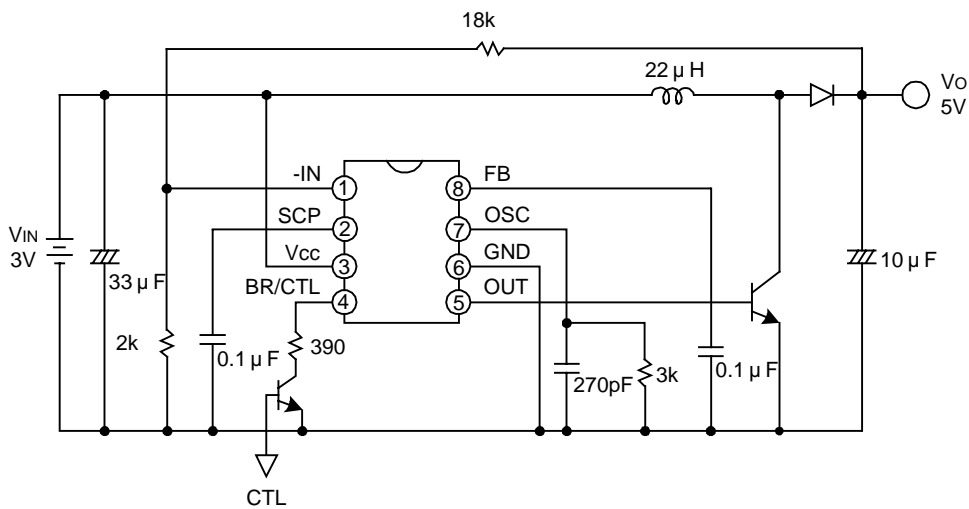

UTC assumes no responsibility for equipment failures that result from using products at values that exceed, even momentarily, rated values (such as maximum ratings, operating condition ranges, or other parameters) listed in products specifications of any and all UTC products described or contained herein. UTC products are not designed for use in life support appliances, devices or systems where malfunction of these products can be reasonably expected to result in personal injury. Reproduction in whole or in part is prohibited without the prior written consent of the copyright owner. The information presented in this document does not form part of any quotation or contract, is believed to be accurate and reliable and may be changed without notice.