



LR1116/B

LINEAR INTEGRATED CIRCUIT

LOW DROP POSITIVE VOLTAGE REGULATORS

■ DESCRIPTION

The UTC **LR1116/B** is a low drop voltage regulator able to provide up to 0.8/0.5A of output current. Output consists of PNP power transistor. So that dropout voltage can be extremely low.

■ FEATURES

- * 2.85V Device are Suitable for SCSI-2 Active Termination
- * Output Current up to 0.8/0.5A
- * Internal Current and Thermal Limit
- * Available in ±1%(at 25°C) and 2% in all Temperature

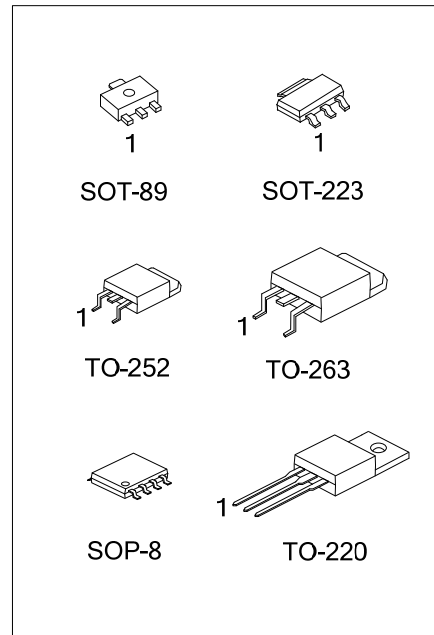

■ ORDERING INFORMATION

Ordering Number		Package	Pin Assignment								Packing	
Lead Free Plating	Halogen Free		1.	2.	3.	4.	5.	6.	7.	8.		
LR1116⓪L-xx-AA3-A-R	LR1116⓪G-xx-AA3-A-R	SOT-223	G	O	I	-	-	-	-	-	-	Tape Reel
LR1116⓪L-xx-AA3-B-R	LR1116⓪G-xx-AA3-B-R	SOT-223	O	G	I	-	-	-	-	-	-	Tape Reel
LR1116⓪L-xx-AA3-C-R	LR1116⓪G-xx-AA3-C-R	SOT-223	G	I	O	-	-	-	-	-	-	Tape Reel
LR1116⓪L-xx-AA3-D-R	LR1116⓪G-xx-AA3-D-R	SOT-223	I	G	O	-	-	-	-	-	-	Tape Reel
LR1116⓪L-xx-AB3-A-R	LR1116⓪G-xx-AB3-A-R	SOT-89	G	O	I	-	-	-	-	-	-	Tape Reel
LR1116⓪L-xx-AB3-B-R	LR1116⓪G-xx-AB3-B-R	SOT-89	O	G	I	-	-	-	-	-	-	Tape Reel
LR1116⓪L-xx-TA3-D-T	LR1116⓪G-xx-TA3-D-T	TO-220	I	G	O	-	-	-	-	-	-	Tube
LR1116⓪L-xx-TN3-A-R	LR1116⓪G-xx-TN3-A-R	TO-252	G	O	I	-	-	-	-	-	-	Tape Reel
LR1116⓪L-xx-TN3-B-R	LR1116⓪G-xx-TN3-B-R	TO-252	O	G	I	-	-	-	-	-	-	Tape Reel
LR1116⓪L-xx-TN3-D-R	LR1116⓪G-xx-TN3-D-R	TO-252	I	G	O	-	-	-	-	-	-	Tape Reel
LR1116⓪L-xx-TQ2-D-R	LR1116⓪G-xx-TQ2-D-R	TO-263	I	G	O	-	-	-	-	-	-	Tape Reel
LR1116⓪L-xx-TQ2-D-T	LR1116⓪G-xx-TQ2-D-T	TO-263	I	G	O	-	-	-	-	-	-	Tube
LR1116⓪L-xx-S08-R	LR1116⓪G-xx-S08-R	SOP-8	G	O	O	I	x	O	O	x	-	Tape Reel

- Notes: 1. ⓪: Current code: Blank: 0.8A B: 0.5A
 2. Pin Assignment: I:V_{IN} O:V_{OUT} G:GND x:NC
 3. xx: Output Voltage, Refer to Marking Information.

<p>LR1116⓪L-xx-AA3-A-R</p>	<p>(1) Packing Type (2) Pin Assignment (3) Package Type (4) Output Voltage Code (5) Lead Free (6) Current Code</p>	<p>(1) R: Tape Reel, T: Tube (2) Refer to Pin Assignment (3) AA3: SOT-223, AB3: SOT-89, TA3: TO-220 TN3: TO-252, TQ2: TO-263, S08: SOP-8 (4) xx: Refer to Marking Information (5) G: Halogen Free, L: Lead Free (6) Blank: 0.8A, B: 0.5A</p>
----------------------------	---	--

MARKING INFORMATION

PACKAGE	VOLTAGE CODE	MARKING
SOT-89		
SOT-223	12 :1.2V 15 :1.5V 18 :1.8V 25 :2.5V 2J :2.85V 30 :3.0V 33 :3.3V 36 :3.6V 50 :5.0V	
TO-220 TO-252 TO-263		

Note: Current code: Blank: 0.8A B:0.5A

■ BLOCK DIAGRAM

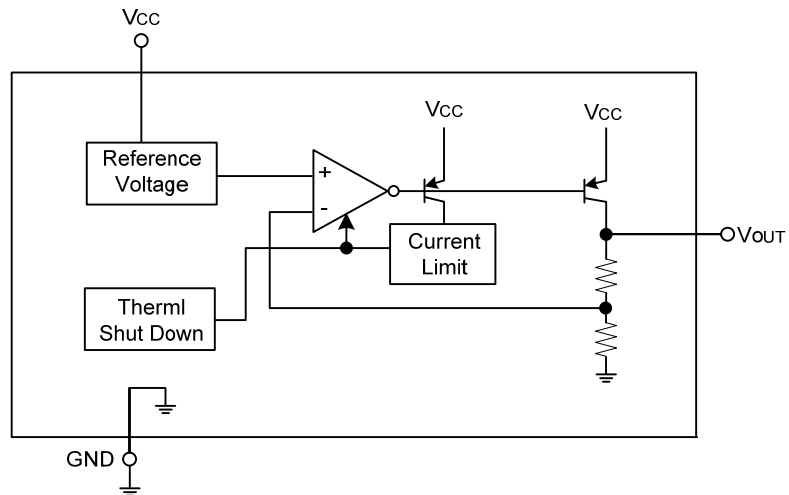

■ APPLICATION CIRCUIT

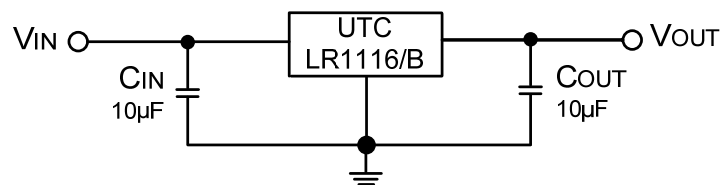

■ ABSOLUTE MAXIMUM RATINGS

PARAMETER	SYMBOL	RATINGS	UNIT
DC Input Voltage	V_{IN}	15	V
Operating Junction Temperature	T_{OPR}	0 ~ +125	°C
Storage Temperature	T_{STG}	-40 ~ +150	°C

Note: Absolute maximum ratings are those values beyond which the device could be permanently damaged.

Absolute maximum ratings are stress ratings only and functional device operation is not implied.

■ THERMAL DATA

PARAMETER	SYMBOL	RATINGS	UNIT
Junction to Case	SOT-223/SOT-89	15	°C/W
	SOP-8	20	°C/W
	TO-252	8	°C/W
	TO-220/TO-263	4	°C/W

■ ELECTRICAL CHARACTERISTICS

($T_a=25^\circ\text{C}$, refer to the test circuits, $T_J=-0\sim 125^\circ\text{C}$, $C_o=10\mu\text{F}$, unless otherwise specified).

For LR1116/B-1.2V

PARAMETER	SYMBOL	TEST CONDITIONS	MIN.	TYP.	MAX.	UNIT	
Output Voltage	V_{OUT}	$V_{IN}=V_{OUT}+1.5\text{V}$, $I_{OUT}=10\text{mA}$, $T_J=25^\circ\text{C}$	1%	1.188	1.2	1.212	V
			2%	1.176		1.224	
Output Voltage	V_{OUT}	$V_{IN}=(V_{OUT}+2\text{V})\sim 15\text{V}$ LR1116 : $I_{OUT}=0$ to 800mA LR1116B : $I_{OUT}=0$ to 500mA	1.176	1.2	1.224	V	
Line Regulation	ΔV_{OUT}	$V_{IN}=(V_{OUT}+2\text{V})\sim 15\text{V}$, $I_{OUT}=0\text{mA}$		0.1	0.6	%	
Load Regulation	ΔV_{OUT}	$V_{IN}=V_{OUT}+2\text{V}$ LR1116 : $I_{OUT}=0$ to 800mA LR1116B : $I_{OUT}=0$ to 500mA		2	3	%	
Temperature Stability	ΔV_{OUT}			0.5		%	
Long Term Stability	ΔV_{OUT}	1000 hrs, $T_J=125^\circ\text{C}$		0.3		%	
Operating Input Voltage	V_{IN}	$I_{OUT}=100\text{mA}$			15	V	
Quiescent Current	I_D	$V_{IN}\leq 10\text{V}$		5	10	mA	
Output Current	I_{OUT}	$V_{IN}=V_{OUT}+4.5\text{V}$, $T_J=25^\circ\text{C}$	800	950	1200	mA	
Output Noise Voltage	eN	$B=10\text{Hz}\sim 10\text{KHz}$, $T_J=25^\circ\text{C}$		100		μV	
Supply Voltage Rejection	SVR	$I_{OUT}=40\text{mA}$, $f=120\text{Hz}$, $T_J=25^\circ\text{C}$ $V_{IN}=V_{OUT}+2.5\text{V}$, $V_{RIPPLE}=1\text{Vpp}$	60	75		dB	
Dropout Voltage	V_D	$I_{OUT}=100\text{mA}$		0.9	1.0	V	
		$I_{OUT}=500\text{mA}$		1.1	1.3	V	
		$I_{OUT}=800\text{mA}$ (only for LR1116)		1.2	1.4	V	
Thermal Regulation		$T_a=25^\circ\text{C}$, 30ms Pulse		0.01	0.10	%/W	

■ ELECTRICAL CHARACTERISTICS (Cont.)

For LR1116/B-1.5V

PARAMETER	SYMBOL	TEST CONDITIONS	MIN.	TYP.	MAX.	UNIT	
Output Voltage	V_{OUT}	$V_{IN}=V_{OUT}+1.5V, I_{OUT}=10mA, T_J=25^{\circ}C$	1%	1.485	1.5	1.515	V
			2%	1.470		1.530	
Output Voltage	V_{OUT}	$V_{IN}=(V_{OUT}+2V)\sim 15V$ LR1116 : $I_{OUT}=0$ to 800mA LR1116B : $I_{OUT}=0$ to 500mA	1.470	1.5	1.530	V	
Line Regulation	ΔV_{OUT}	$V_{IN}=(V_{OUT}+2V)\sim 15V, I_{OUT}=0mA$		0.1	0.6	%	
Load Regulation	ΔV_{OUT}	$V_{IN}=V_{OUT}+2V$ LR1116 : $I_{OUT}=0$ to 800mA LR1116B : $I_{OUT}=0$ to 500mA		2	3	%	
Temperature Stability	ΔV_{OUT}			0.5		%	
Long Term Stability	ΔV_{OUT}	1000 hrs, $T_J=125^{\circ}C$		0.3		%	
Operating Input Voltage	V_{IN}	$I_{OUT}=100mA$			15	V	
Quiescent Current	I_D	$V_{IN}\leq 10V$		5	10	mA	
Output Current	I_{OUT}	$V_{IN}=V_{OUT}+4.5V, T_J=25^{\circ}C$	800	950	1200	mA	
Output Noise Voltage	eN	$B=10Hz\sim 10KHz, T_J=25^{\circ}C$		100		μV	
Supply Voltage Rejection	SVR	$I_{OUT}=40mA, f=120Hz, T_J=25^{\circ}C$ $V_{IN}=V_{OUT}+2.5V, V_{RIPPLE}=1V_{pp}$	60	75		dB	
Dropout Voltage	V_D	$I_{OUT}=100mA$		0.6	0.75	V	
		$I_{OUT}=500mA$		0.80	0.95	V	
		$I_{OUT}=800mA$ (only for LR1116)		0.95	1.1	V	
Thermal Regulation		$T_a=25^{\circ}C, 30ms$ Pulse		0.01	0.10	%/W	

For LR1116/B-1.8V

PARAMETER	SYMBOL	TEST CONDITIONS	MIN.	TYP.	MAX.	UNIT	
Output Voltage	V_{OUT}	$V_{IN}=V_{OUT}+1.5V, I_{OUT}=10mA, T_J=25^{\circ}C$	1%	1.782	1.8	1.818	V
			2%	1.764		1.836	
Output Voltage	V_{OUT}	$V_{IN}=(V_{OUT}+2V)\sim 15V$ LR1116 : $I_{OUT}=0$ to 800mA LR1116B : $I_{OUT}=0$ to 500mA	1.764	1.8	1.836	V	
Line Regulation	ΔV_{OUT}	$V_{IN}=(V_{OUT}+2V)\sim 15V, I_{OUT}=0mA$		0.1	0.6	%	
Load Regulation	ΔV_{OUT}	$V_{IN}=V_{OUT}+2V$ LR1116 : $I_{OUT}=0$ to 800mA LR1116B : $I_{OUT}=0$ to 500mA		2	3	%	
Temperature Stability	ΔV_{OUT}			0.5		%	
Long Term Stability	ΔV_{OUT}	1000 hrs, $T_J=125^{\circ}C$		0.3		%	
Operating Input Voltage	V_{IN}	$I_{OUT}=100mA$			15	V	
Quiescent Current	I_D	$V_{IN}\leq 10V$		5	10	mA	
Output Current	I_{OUT}	$V_{IN}=V_{OUT}+4.5V, T_J=25^{\circ}C$	800	950	1200	mA	
Output Noise Voltage	eN	$B=10Hz\sim 10KHz, T_J=25^{\circ}C$		100		μV	
Supply Voltage Rejection	SVR	$I_{OUT}=40mA, f=120Hz, T_J=25^{\circ}C$ $V_{IN}=V_{OUT}+2.5V, V_{RIPPLE}=1V_{pp}$	60	75		dB	
Dropout Voltage	V_D	$I_{OUT}=100mA$		0.4	0.5	V	
		$I_{OUT}=500mA$		0.6	0.8	V	
		$I_{OUT}=800mA$ (only for LR1116)		0.8	0.95	V	
Thermal Regulation		$T_a=25^{\circ}C, 30ms$ Pulse		0.01	0.10	%/W	

■ ELECTRICAL CHARACTERISTICS (Cont.)

For LR1116/B-2.5V

PARAMETER	SYMBOL	TEST CONDITIONS	MIN.	TYP.	MAX.	UNIT	
Output Voltage	V _{OUT}	V _{IN} =V _{OUT} +1.5V, I _{OUT} =10mA, T _J =25°C	1%	2.475	2.5	2.525	V
			2%	2.450		2.550	
Output Voltage	V _{OUT}	V _{IN} =(V _{OUT} +2V)~15V LR1116 : I _{OUT} =0 to 800mA LR1116B : I _{OUT} =0 to 500mA	2.45	2.5	2.55	V	
Line Regulation	ΔV _{OUT}	V _{IN} =(V _{OUT} +2V)~15V, I _{OUT} =0mA		0.1	0.6	%	
Load Regulation	ΔV _{OUT}	V _{IN} =V _{OUT} +2V LR1116 : I _{OUT} =0 to 800mA LR1116B : I _{OUT} =0 to 500mA		2	3	%	
Temperature Stability	ΔV _{OUT}			0.5		%	
Long Term Stability	ΔV _{OUT}	1000 hrs, T _J =125°C		0.3		%	
Operating Input Voltage	V _{IN}	I _{OUT} =100mA			15	V	
Quiescent Current	I _D	V _{IN} ≤10V		5	10	mA	
Output Current	I _{OUT}	V _{IN} =V _{OUT} +4.5V, T _J =25°C	800	950	1200	mA	
Output Noise Voltage	eN	B=10Hz~10KHz, T _J =25°C		100		μV	
Supply Voltage Rejection	SVR	I _{OUT} =40mA, f=120Hz, T _J =25°C V _{IN} =V _{OUT} +2.5V, V _{RIPPLE} =1Vpp	60	75		dB	
Dropout Voltage	V _D	I _{OUT} = 100mA		0.16	0.3	V	
		I _{OUT} = 500mA		0.4	0.6	V	
		I _{OUT} = 800mA(only for LR1116)		0.6	0.8	V	
Thermal Regulation		T _a =25°C, 30ms Pulse		0.01	0.10	%/W	

For LR1116/B-2.85V

PARAMETER	SYMBOL	TEST CONDITIONS	MIN.	TYP.	MAX.	UNIT	
Output Voltage	V _{OUT}	V _{IN} =V _{OUT} +1.5V, I _{OUT} =10mA, T _J =25°C	1%	2.822	2.85	2.878	V
			2%	2.793		2.907	
Output Voltage	V _{OUT}	V _{IN} =(V _{OUT} +2V)~15V LR1116 : I _{OUT} =0 to 800mA LR1116B : I _{OUT} =0 to 500mA	2.793	2.85	2.907	V	
Line Regulation	ΔV _{OUT}	V _{IN} =(V _{OUT} +2V)~15V, I _{OUT} =0mA		0.1	0.6	%	
Load Regulation	ΔV _{OUT}	V _{IN} =V _{OUT} +2V LR1116 : I _{OUT} =0 to 800mA LR1116B : I _{OUT} =0 to 500mA		2	3	%	
Temperature Stability	ΔV _{OUT}			0.5		%	
Long Term Stability	ΔV _{OUT}	1000 hrs, T _J =125°C		0.3		%	
Operating Input Voltage	V _{IN}	I _{OUT} =100mA			15	V	
Quiescent Current	I _D	V _{IN} ≤10V		5	10	mA	
Output Current	I _{OUT}	V _{IN} =V _{OUT} +4.5V, T _J =25°C	800	950	1200	mA	
Output Noise Voltage	eN	B=10Hz~10KHz, T _J =25°C		100		μV	
Supply Voltage Rejection	SVR	I _{OUT} =40mA, f=120Hz, T _J =25°C V _{IN} =V _{OUT} +2.5V, V _{RIPPLE} =1Vpp	60	75		dB	
Dropout Voltage	V _D	I _{OUT} = 100mA		0.16	0.3	V	
		I _{OUT} = 500mA		0.45	0.6	V	
		I _{OUT} = 800mA(only for LR1116)		0.6	0.8	V	
Thermal Regulation		T _a =25°C, 30ms Pulse		0.01	0.10	%/W	

■ ELECTRICAL CHARACTERISTICS (Cont.)

For LR1116/B-3.0V

PARAMETER	SYMBOL	TEST CONDITIONS	MIN.	TYP.	MAX.	UNIT
Output Voltage	V_{OUT}	$V_{IN}=V_{OUT}+1.5V, I_{OUT}=10mA, T_J=25^{\circ}C$	2.970	3.0	3.030	V
Output Voltage	V_{OUT}	$V_{IN}=(V_{OUT}+2V)\sim 15V$ LR1116 : $I_{OUT}=0$ to 800mA LR1116B : $I_{OUT}=0$ to 500mA	2.940	3.0	3.060	V
Line Regulation	ΔV_{OUT}	$V_{IN}=(V_{OUT}+2V)\sim 15V, I_{OUT}=0mA$		0.1	0.6	%
Load Regulation	ΔV_{OUT}	$V_{IN}=V_{OUT}+2V$ LR1116 : $I_{OUT}=0$ to 800mA LR1116B : $I_{OUT}=0$ to 500mA		2	3	%
Temperature Stability	ΔV_{OUT}			0.5		%
Long Term Stability	ΔV_{OUT}	1000 hrs, $T_J=125^{\circ}C$		0.3		%
Operating Input Voltage	V_{IN}	$I_{OUT}=100mA$			15	V
Quiescent Current	I_D	$V_{IN}\leq 10V$		5	10	mA
Output Current	I_{OUT}	$V_{IN}=V_{OUT}+4.5V, T_J=25^{\circ}C$	800	950	1200	mA
Output Noise Voltage	eN	$B=10Hz \sim 10KHz, T_J=25^{\circ}C$		100		μV
Supply Voltage Rejection	SVR	$I_{OUT}=40mA, f=120Hz, T_J=25^{\circ}C$ $V_{IN}=V_{OUT}+2.5V, V_{RIPPLE}=1V_{pp}$	60	75		dB
Dropout Voltage	V_D	$I_{OUT}= 100mA$		0.16	0.3	V
		$I_{OUT}= 500mA$		0.45	0.6	V
		$I_{OUT}= 800mA$ (only for LR1116)		0.6	0.8	V
Thermal Regulation		$T_a=25^{\circ}C, 30ms$ Pulse		0.01	0.10	%/W

For LR1116/B-3.3V

PARAMETER	SYMBOL	TEST CONDITIONS	MIN.	TYP.	MAX.	UNIT
Output Voltage	V_{OUT}	$V_{IN}=V_{OUT}+1.5V, I_{OUT}=10mA, T_J=25^{\circ}C$	3.267	3.3	3.333	V
Output Voltage	V_{OUT}	$V_{IN}=(V_{OUT}+2V)\sim 15V$ LR1116 : $I_{OUT}=0$ to 800mA LR1116B : $I_{OUT}=0$ to 500mA	3.234	3.3	3.366	V
Line Regulation	ΔV_{OUT}	$V_{IN}=(V_{OUT}+2V)\sim 15V, I_{OUT}=0mA$		0.1	0.6	%
Load Regulation	ΔV_{OUT}	$V_{IN}=V_{OUT}+2V$ LR1116 : $I_{OUT}=0$ to 800mA LR1116B : $I_{OUT}=0$ to 500mA		2	3	%
Temperature Stability	ΔV_{OUT}			0.5		%
Long Term Stability	ΔV_{OUT}	1000 hrs, $T_J=125^{\circ}C$		0.3		%
Operating Input Voltage	V_{IN}	$I_{OUT}=100mA$			15	V
Quiescent Current	I_D	$V_{IN}\leq 10V$		5	10	mA
Output Current	I_{OUT}	$V_{IN}=V_{OUT}+4.5V, T_J=25^{\circ}C$	800	950	1200	mA
Output Noise Voltage	eN	$B=10Hz \sim 10KHz, T_J=25^{\circ}C$		100		μV
Supply Voltage Rejection	SVR	$I_{OUT}=40mA, f=120Hz, T_J=25^{\circ}C$ $V_{IN}=V_{OUT}+2.5V, V_{RIPPLE}=1V_{pp}$	60	75		dB
Dropout Voltage	V_D	$I_{OUT}= 100mA$		0.16	0.3	V
		$I_{OUT}= 500mA$		0.4	0.6	V
		$I_{OUT}= 800mA$ (only for LR1116)		0.6	0.8	V
Thermal Regulation		$T_a=25^{\circ}C, 30ms$ Pulse		0.01	0.10	%/W

■ ELECTRICAL CHARACTERISTICS (Cont.)

For LR1116/B-3.6V

PARAMETER	SYMBOL	TEST CONDITIONS	MIN.	TYP.	MAX.	UNIT
Output Voltage	V_{OUT}	$V_{IN}=V_{OUT}+1.5V, I_{OUT}=10mA, T_J=25^{\circ}C$	3.564	3.6	3.636	V
Output Voltage	V_{OUT}	$V_{IN}=(V_{OUT}+2V)\sim 15V$ LR1116 : $I_{OUT}=0$ to 800mA LR1116B : $I_{OUT}=0$ to 500mA	3.528	3.6	3.672	V
Line Regulation	ΔV_{OUT}	$V_{IN}=(V_{OUT}+2V)\sim 15V, I_{OUT}=0mA$		0.1	0.6	%
Load Regulation	ΔV_{OUT}	$V_{IN}=V_{OUT}+2V$ LR1116 : $I_{OUT}=0$ to 800mA LR1116B : $I_{OUT}=0$ to 500mA		2	3	%
Temperature Stability	ΔV_{OUT}			0.5		%
Long Term Stability	ΔV_{OUT}	1000 hrs, $T_J=125^{\circ}C$		0.3		%
Operating Input Voltage	V_{IN}	$I_{OUT}=100mA$			15	V
Quiescent Current	I_D	$V_{IN}\leq 10V$		5	10	mA
Output Current	I_{OUT}	$V_{IN}=V_{OUT}+4.5V, T_J=25^{\circ}C$	800	950	1200	mA
Output Noise Voltage	eN	$B=10Hz \sim 10KHz, T_J=25^{\circ}C$		100		μV
Supply Voltage Rejection	SVR	$I_{OUT}=40mA, f=120Hz, T_J=25^{\circ}C$ $V_{IN}=V_{OUT}+2.5V, V_{RIPPLE}=1V_{pp}$	60	75		dB
Dropout Voltage	V_D	$I_{OUT}= 100mA$		0.16	0.3	V
		$I_{OUT}= 500mA$		0.4	0.6	V
		$I_{OUT}= 800mA$ (only for LR1116)		0.6	0.8	V
Thermal Regulation		$T_a=25^{\circ}C, 30ms$ Pulse		0.01	0.10	%/W

For LR1116/B-5.0V

PARAMETER	SYMBOL	TEST CONDITIONS	MIN.	TYP.	MAX.	UNIT
Output Voltage	V_{OUT}	$V_{IN}=V_{OUT}+1.5V, I_{OUT}=10mA, T_J=25^{\circ}C$	4.95	5.0	5.05	V
Output Voltage	V_{OUT}	$V_{IN}=(V_{OUT}+2V)\sim 15V$ LR1116 : $I_{OUT}=0$ to 800mA LR1116B : $I_{OUT}=0$ to 500mA	4.90	5.0	5.10	V
Line Regulation	ΔV_{OUT}	$V_{IN}=(V_{OUT}+2V)\sim 15V, I_{OUT}=0mA$		0.1	0.6	%
Load Regulation	ΔV_{OUT}	$V_{IN}=V_{OUT}+2V$ LR1116 : $I_{OUT}=0$ to 800mA LR1116B : $I_{OUT}=0$ to 500mA		2	3	%
Temperature Stability	ΔV_{OUT}			0.5		%
Long Term Stability	ΔV_{OUT}	1000 hrs, $T_J=125^{\circ}C$		0.3		%
Operating Input Voltage	V_{IN}	$I_{OUT}=100mA$			15	V
Quiescent Current	I_D	$V_{IN}\leq 10V$		5	10	mA
Output Current	I_{OUT}	$V_{IN}=V_{OUT}+4.5V, T_J=25^{\circ}C$	800	950	1200	mA
Output Noise Voltage	eN	$B=10Hz \sim 10KHz, T_J=25^{\circ}C$		100		μV
Supply Voltage Rejection	SVR	$I_{OUT}=40mA, f=120Hz, T_J=25^{\circ}C$ $V_{IN}=V_{OUT}+2.5V, V_{RIPPLE}=1V_{pp}$	60	75		dB
Dropout Voltage	V_D	$I_{OUT}= 100mA$		0.16	0.3	V
		$I_{OUT}= 500mA$		0.4	0.6	V
		$I_{OUT}= 800mA$ (only for LR1116)		0.6	0.8	V
Thermal Regulation		$T_a=25^{\circ}C, 30ms$ Pulse		0.01	0.10	%/W

TYPICAL PERFORMANCE CHARACTERISTICS

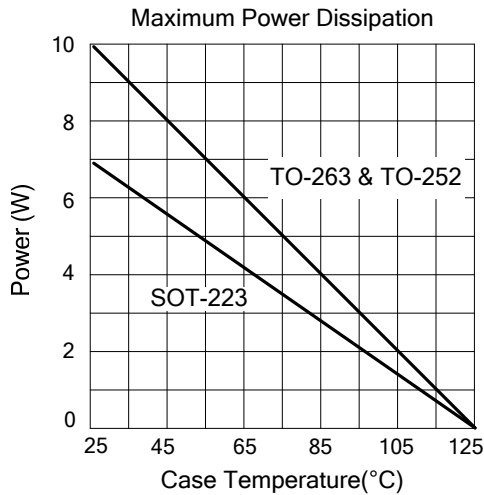
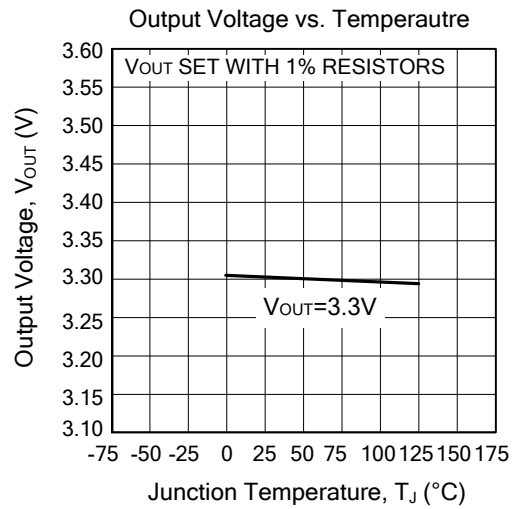
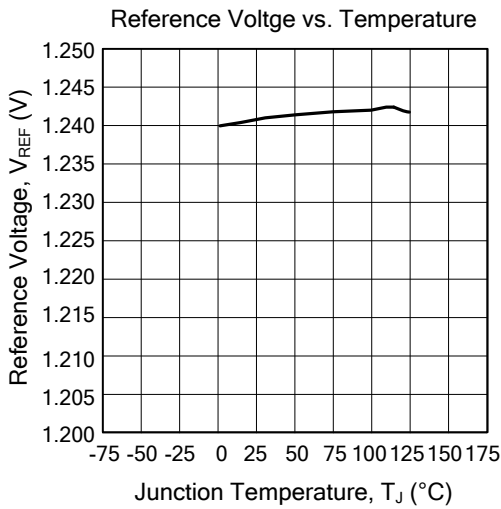

UTC assumes no responsibility for equipment failures that result from using products at values that exceed, even momentarily, rated values (such as maximum ratings, operating condition ranges, or other parameters) listed in products specifications of any and all UTC products described or contained herein. UTC products are not designed for use in life support appliances, devices or systems where malfunction of these products can be reasonably expected to result in personal injury. Reproduction in whole or in part is prohibited without the prior written consent of the copyright owner. The information presented in this document does not form part of any quotation or contract, is believed to be accurate and reliable and may be changed without notice.