



MMBT9013

NPN SILICON TRANSISTOR

1W OUTPUT AMPLIFIER OF
POTABLE RADIOS IN CLASS
B PUSH-PULL OPERATION

■ FEATURES

- *High total Power Dissipation. (625mW)
- *High Collector Current. (500mA)
- *Excellent h_{FE} linearity.
- *Complementary to UTC MMBT9012

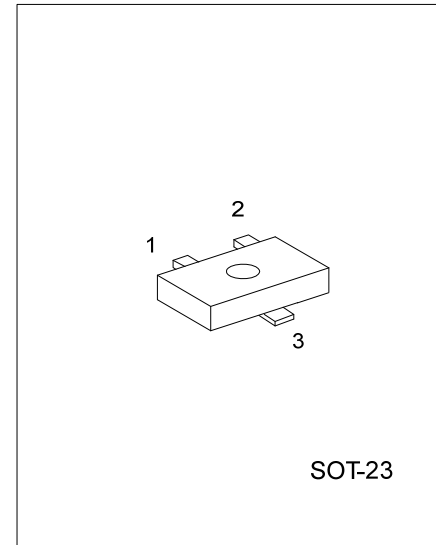

*Pb-free plating product number:
MMBT9013L

■ ORDERING INFORMATION

| Ordering Number | | Package | Pin Assignment | | | Packing |
|------------------|-------------------|---------|----------------|---|---|-----------|
| Normal | Lead Free Plating | | 1 | 2 | 3 | |
| MMBT9013-x-AE3-R | MMBT9013L-x-AE3-R | SOT-23 | E | B | C | Tape Reel |

| | |
|---|--|
| <p>MMBT9013L-x-AE3-R</p> <p>(1)Packing Type (2)Package Type (3)Rank (4)Lead Plating</p> | <p>(1) R: Tape Reel (2) AE3: SOT-23 (3) x: refer to Classification of h_{FE} (4) L: Lead Free Plating, Blank: Pb/Sn</p> |
|---|--|

■ MARKING

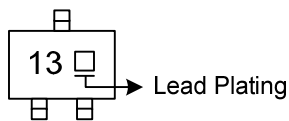

MMBT9013

NPN SILICON TRANSISTOR

■ ABSOLUTE MAXIMUM RATINGS (Ta=25°C, unless otherwise specified)

| PARAMETER | SYMBOL | RATING | UNIT |
|---------------------------|------------------|------------|------|
| Collector-Base Voltage | V _{CBO} | 40 | V |
| Collector-Emitter Voltage | V _{CEO} | 20 | V |
| Emitter-Base Voltage | V _{EBO} | 5 | V |
| Collector Current | I _C | 500 | mA |
| Collector Dissipation | P _C | 225 | mW |
| Junction Temperature | T _J | +150 | °C |
| Storage Temperature | T _{STG} | -55 ~ +150 | °C |

■ ELECTRICAL CHARACTERISTICS (Ta=25°C, unless otherwise specified)

| PARAMETER | SYMBOL | TEST CONDITIONS | MIN | TYP | MAX | UNIT |
|--------------------------------------|----------------------|---|-----|------|-----|------|
| Collector-Base Breakdown Voltage | BV _{CBO} | I _C =100μA, I _E =0 | 40 | | | V |
| Collector-Emitter Breakdown Voltage | BV _{CEO} | I _C =1mA, I _B =0 | 20 | | | V |
| Emitter-Base Breakdown Voltage | BV _{EBO} | I _E =100μA, I _C =0 | 5 | | | V |
| Collector-Emitter Saturation Voltage | V _{CE(SAT)} | I _C =500mA, I _B =50mA | | 0.16 | 0.6 | V |
| Base-Emitter Saturation Voltage | V _{BE(SAT)} | I _C =500mA, I _B =50mA | | 0.91 | 1.2 | V |
| Base-Emitter On Voltage | V _{BE(ON)} | V _{CE} =1V, I _C =10mA | 0.6 | 0.67 | 0.7 | V |
| Collector Cutoff Current | I _{CBO} | V _{CB} =25V, I _E =0 | | | 100 | nA |
| Emitter Cutoff Current | I _{EBO} | V _{EB} =3V, I _C =0 | | | 100 | nA |
| DC Current Gain | h _{FE1} | V _{CE} =1V, I _C =50mA | 64 | 120 | 300 | |
| | h _{FE2} | V _{CE} =1V, I _C =500mA | 40 | 120 | | |

■ CLASSIFICATION OF h_{FE1}

| RANK | D | E | F | G | H | I |
|-------|-------|--------|--------|---------|---------|---------|
| RANGE | 64-91 | 78-112 | 96-135 | 112-166 | 144-202 | 190-300 |

TYPICAL CHARACTERISTICS

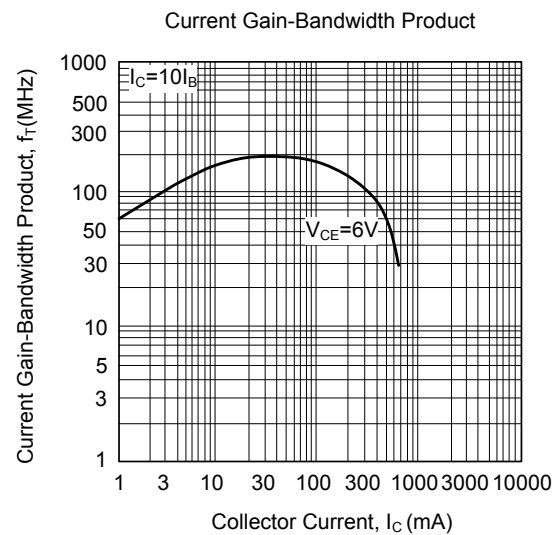
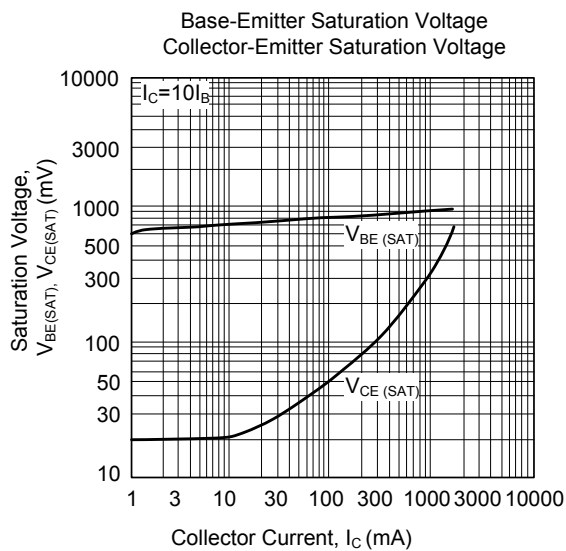
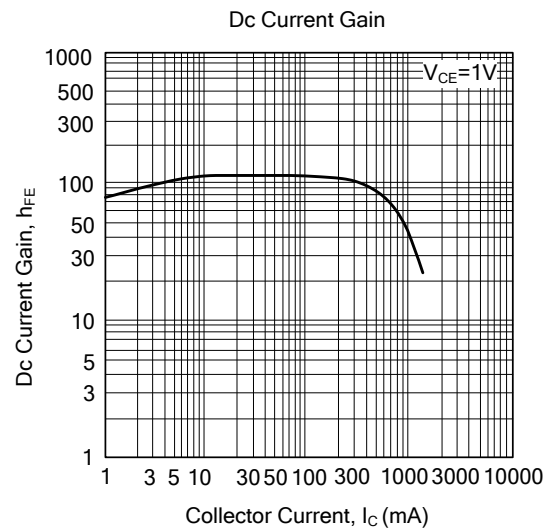
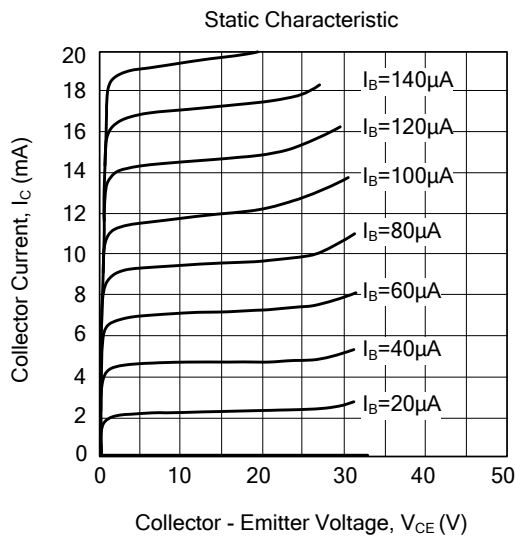

UTC assumes no responsibility for equipment failures that result from using products at values that exceed, even momentarily, rated values (such as maximum ratings, operating condition ranges, or other parameters) listed in products specifications of any and all UTC products described or contained herein. UTC products are not designed for use in life support appliances, devices or systems where malfunction of these products can be reasonably expected to result in personal injury. Reproduction in whole or in part is prohibited without the prior written consent of the copyright owner. The information presented in this document does not form part of any quotation or contract, is believed to be accurate and reliable and may be changed without notice.