



MMBT9014

NPN SILICON TRANSISTOR

PRE-AMPLIFIER, LOW LEVEL & LOW NOISE

■ FEATURES

- * High Total Power Dissipation. (450mW)
- * Excellent h_{FE} Linearity.
- * Complementary to UTC MMBT9015

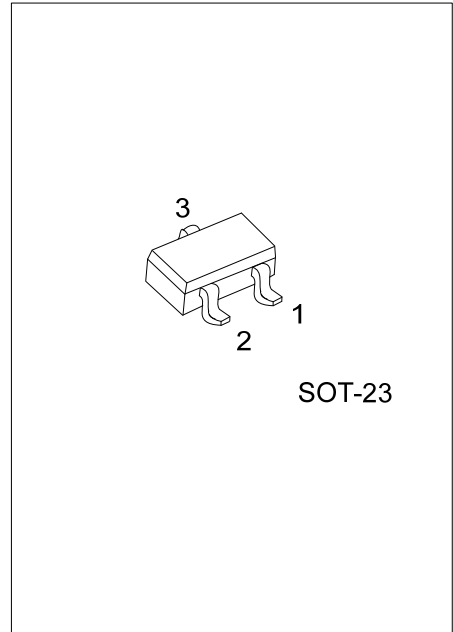

■ ORDERING INFORMATION

Ordering Number	Package	Pin Assignment			Packing
		1	2	3	
MMBT9014G-x-AE3-R	SOT-23	E	B	C	Tape Reel

<p>MMBT9014G-x-AE3-R</p>	<p>(1) R: Tape Reel (2) AE3: SOT-23 (3) x: refer to Classification of h_{FE} (4) G: Halogen Free</p>
--------------------------	--

■ MARKING

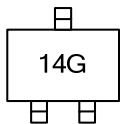

MMBT9014

NPN SILICON TRANSISTOR

■ ABSOLUTE MAXIMUM RATINGS ($T_a=25^{\circ}\text{C}$, unless otherwise specified)

PARAMETER	SYMBOL	RATINGS	UNIT
Collector-Emitter Voltage	V_{CEO}	45	V
Collector-Base Voltage	V_{CBO}	50	V
Emitter Base Voltage	V_{EBO}	5	V
Collector Current	I_C	100	mA
Collector dissipation	P_C	225	mW
Junction Temperature	T_J	150	$^{\circ}\text{C}$
Storage Temperature	T_{STG}	-55 ~ +150	$^{\circ}\text{C}$

Note: Absolute maximum ratings are those values beyond which the device could be permanently damaged.
Absolute maximum ratings are stress ratings only and functional device operation is not implied.

■ ELECTRICAL CHARACTERISTICS ($T_a=25^{\circ}\text{C}$, unless otherwise specified)

PARAMETER	SYMBOL	TEST CONDITIONS	MIN	TYP	MAX	UNIT
Collector-Emitter Voltage	V_{CEO}	$I_C=100\mu\text{A}, I_E=0$	50			V
Collector-Base Voltage	V_{CBO}	$I_C=1\text{mA}, I_B=0$	45			V
Emitter Base Voltage	V_{EBO}	$I_E=100\mu\text{A}, I_C=0$	5			V
Collector cutoff current	I_{CBO}	$V_{CB}=50\text{V}, I_E=0$			50	nA
Emitter Cutoff Current	I_{EBO}	$V_{EB}=5\text{V}, I_C=0$			100	nA
DC Current Gain	h_{FE}	$V_{CE}=5\text{V}, I_C=1\text{mA}$	60	280	1000	
Collector-Emitter Saturation Voltage	$V_{CE(SAT)}$	$I_C=100\text{mA}, I_B=5\text{mA}$		0.14	0.3	V
Base-Emitter Saturation Voltage	$V_{BE(SAT)}$	$I_C=100\text{mA}, I_B=5\text{mA}$		0.84	1.0	V
Base-emitter on voltage	$V_{BE(ON)}$	$V_{CE}=5\text{V}, I_C=2\text{mA}$	0.58	0.63	0.7	V
Current-Gain-Bandwidth Product	f_T	$V_{CE}=5\text{V}, I_C=10\text{mA}$	150	270		MHz
Output Capacitance	C_{OB}	$V_{CB}=10\text{V}, I_E=0, f=1\text{MHz}$		2.2	3.5	pF
Noise Figure	NF	$V_{CE}=5\text{V}, I_C=0.2\text{mA}, f=1\text{KHz}, R_S=2\text{K}\Omega$		0.9	10	dB

■ CLASSIFICATION OF h_{FE}

RANK	A	B	C	D
RANGE	60-150	100-300	200-600	400-1000

TYPICAL CHARACTERISTICS

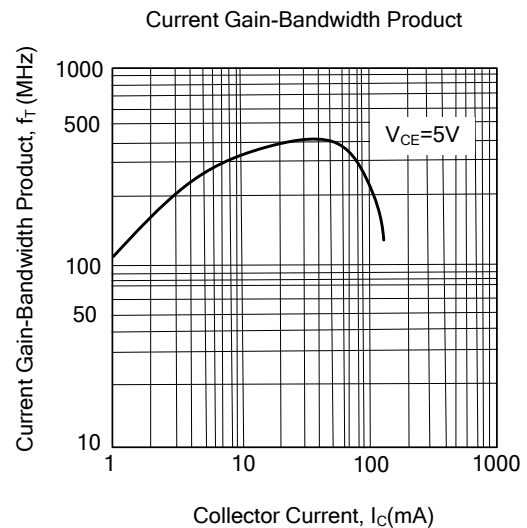
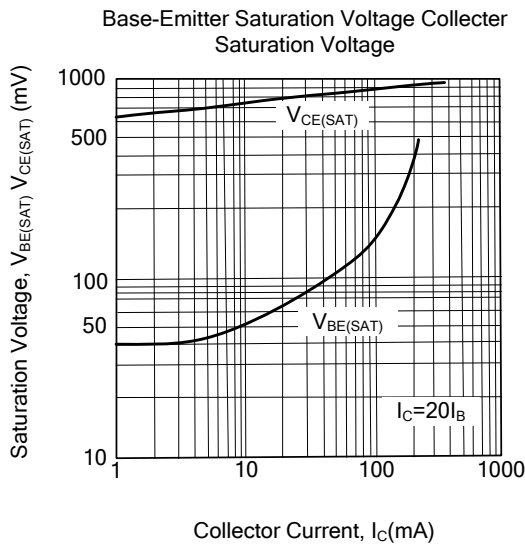
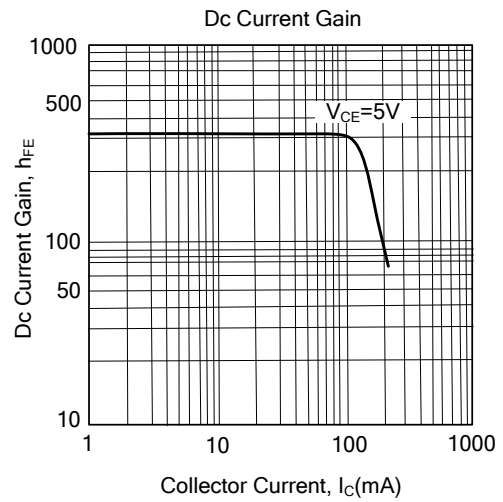
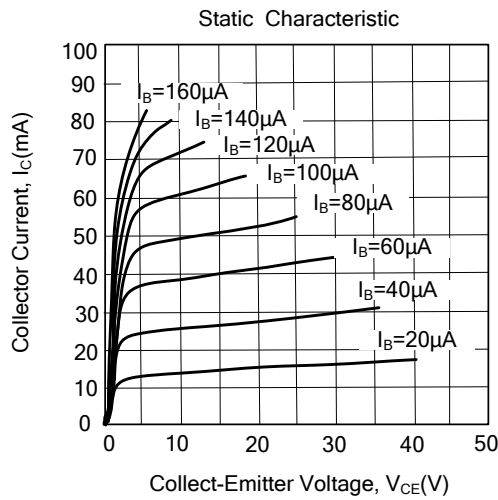

UTC assumes no responsibility for equipment failures that result from using products at values that exceed, even momentarily, rated values (such as maximum ratings, operating condition ranges, or other parameters) listed in products specifications of any and all UTC products described or contained herein. UTC products are not designed for use in life support appliances, devices or systems where malfunction of these products can be reasonably expected to result in personal injury. Reproduction in whole or in part is prohibited without the prior written consent of the copyright owner. The information presented in this document does not form part of any quotation or contract, is believed to be accurate and reliable and may be changed without notice.