



TIP42C

PNP PLANAR TRANSISTOR

PNP EPITAXIAL PLANAR TRANSISTOR

■ DESCRIPTION

The UTC **TIP42C** is a PNP epitaxial planar transistor, designed for using in general purpose amplifier and switching applications.

■ FEATURES

* Complement to TIP41C

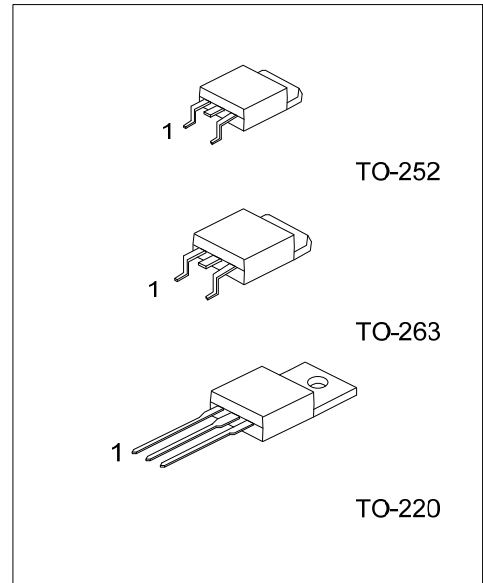

Lead-free: TIP42CL
Halogen-free: TIP42CG

■ ORDERING INFORMATION

Ordering Number			Package	Pin Assignment			Packing
Normal	Lead Free	Halogen Free		1	2	3	
TIP42C-TA3-T	TIP42CL-TA3-T	TIP42CG-TA3-T	TO-220	B	C	E	Tube
TIP42C-TN3-R	TIP42CL-TN3-R	TIP42CG-TN3-R	TO-252	B	C	E	Tape Reel
TIP42C-TQ2-R	TIP42CL-TQ2-R	TIP42CG-TQ2-R	TO-263	B	C	E	Tape Reel
TIP42C-TQ2-T	TIP42CL-TQ2-T	TIP42CG-TQ2-T	TO-263	B	C	E	Tube

<p>TIP42CL-TA3-T</p> <p>(1) Packing Type (2) Package Type (3) Lead Plating</p>	<p>(1) T: Tube, R: Tape Reel (2) TA3: TO-220, TN3: TO-252, TQ2: TO-263 (3) G: Halogen Free, L: Lead Free, Blank: Pb/Sn</p>
--	--

■ ABSOLUTE MAXIMUM RATING

PARAMETER		SYMBOL	RATINGS	UNIT
Collector Base Voltage		V_{CBO}	-100	V
Collector to Emitter Voltage		V_{CEO}	-100	V
Emitter-Base Voltage		V_{EBO}	-5	V
Collector Current (DC)		I_C	-6	A
Collector Current (Pulse)		I_C	-10	A
Base Current		I_B	-2	A
Collector Dissipation ($T_C=25^\circ\text{C}$)	TO-220/TO-263	P_C	65	W
	TO-252		20	W
Junction Temperature		T_J	+150	$^\circ\text{C}$
Storage Temperature		T_{STG}	-65 ~ +150	$^\circ\text{C}$

Note Absolute maximum ratings are those values beyond which the device could be permanently damaged. Absolute maximum ratings are stress ratings only and functional device operation is not implied.

■ ELECTRICAL CHARACTERISTICS ($T_C=25^\circ\text{C}$)

PARAMETER	SYMBOL	TEST CONDITIONS	MIN	TYP	MAX	UNIT
Collector-Emitter Breakdown Voltage (Note)	BV_{CEO}	$I_C=-30\text{mA}, I_B=0$	-100			V
Collector Cutoff Current	I_{CEO}	$V_{CE}=-60\text{V}, I_B=0$			-0.7	mA
Collector Cutoff Current	I_{CES}	$V_{CE}=-100\text{V}, V_{EB}=0$			-400	μA
Emitter Cutoff Current	I_{EBO}	$V_{BE}=-5\text{V}, I_C=0$			-1	mA
Collector-Emitter Saturation Voltage (Note)	$V_{CE(SAT)}$	$I_C=-6\text{A}, I_B=-600\text{mA}$			-1.5	V
Base-Emitter on Voltage (Note)	$V_{BE(ON)}$	$V_{CE}=-4\text{V}, I_C=-6\text{A}$			-2.0	V
DC Current Gain (Note)	h_{FE}	$V_{CE}=-4\text{V}, I_C=-300\text{mA}$	30			
		$V_{CE}=-4\text{V}, I_C=-3\text{A}$	15		75	
Current Gain Bandwidth Product	f_T	$V_{CE}=-10\text{V}, I_C=-500\text{mA}, f=1\text{MHz}$	3			MHz

Note: Pulse Test: $PW \leq 300\mu\text{s}$, Duty Cycle $\leq 2\%$

TYPICAL CHARACTERISTICS

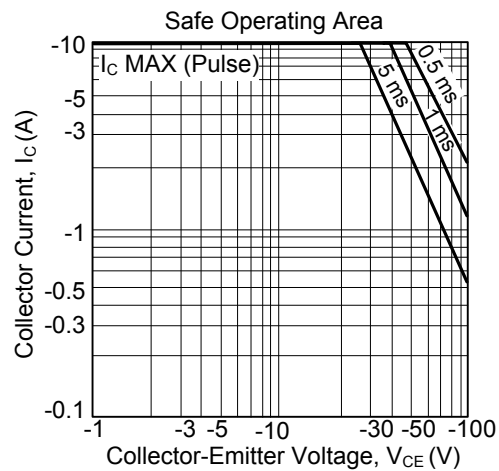
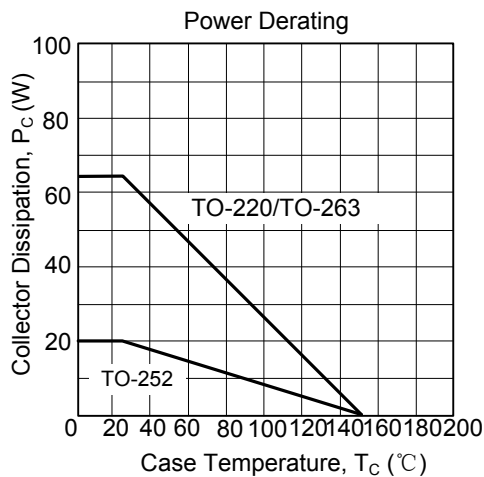
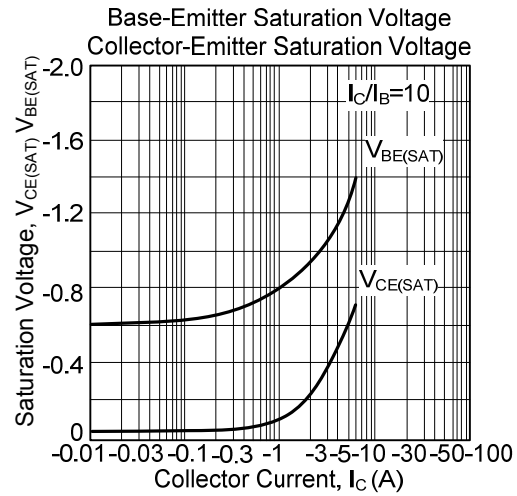
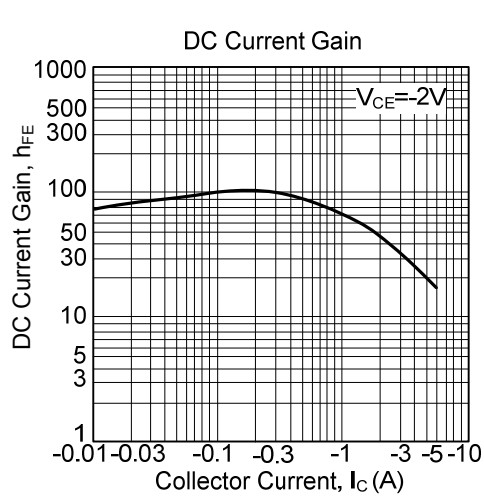

UTC assumes no responsibility for equipment failures that result from using products at values that exceed, even momentarily, rated values (such as maximum ratings, operating condition ranges, or other parameters) listed in products specifications of any and all UTC products described or contained herein. UTC products are not designed for use in life support appliances, devices or systems where malfunction of these products can be reasonably expected to result in personal injury. Reproduction in whole or in part is prohibited without the prior written consent of the copyright owner. The information presented in this document does not form part of any quotation or contract, is believed to be accurate and reliable and may be changed without notice.