



U74LVC1G17

CMOS IC

SINGLE SCHMITT-TRIGGER BUFFER

DESCRIPTION

The UTC **U74LVC1G17** is a single Schmitt-trigger buffer, it provides the function $Y=A$.

The device have different input threshold levels for positive-going (V_{T+}) and negative-going (V_{T-}) signals because of the Schmitt-trigger action in the input.

This device has power-down protective circuit, preventing device destruction when it is powered down.

FEATURES

- * Operation Voltage Range: 1.65~5.5V
- * Low Power Dissipation: $I_{CC}=10\mu A$ (Max)
- * 24mA Output Drive ($V_{CC}=3.0V$)
- * High Noise Immunity $I_{CC}=10\mu A$ (Max)
- * Power Down Protection $I_{CC}=10\mu A$ (Max)

ORDERING INFORMATION

Order Number		Package	Packing
Lead Free	Halogen Free		
U74LVC1G17L-AF5-R	U74LVC1G17G-AF5-R	SOT-25	Tape Reel
U74LVC1G17L-AL5-R	U74LVC1G17G-AL5-R	SOT-353	Tape Reel

<p>U74LVC1G17L-AF5-R</p> <p>(1) Packing Type (2) Package Type (3) Lead Plating</p>	<p>(1) R: Tape Reel (2) AF5: SOT-25, AL5: SOT-353 (3) G: Halogen Free, L: Lead Free</p>
--	---

MARKING

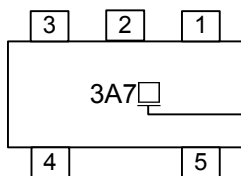

SOT-25

L: Lead Free
G: Halogen Free

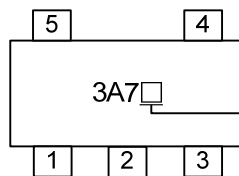

SOT-353

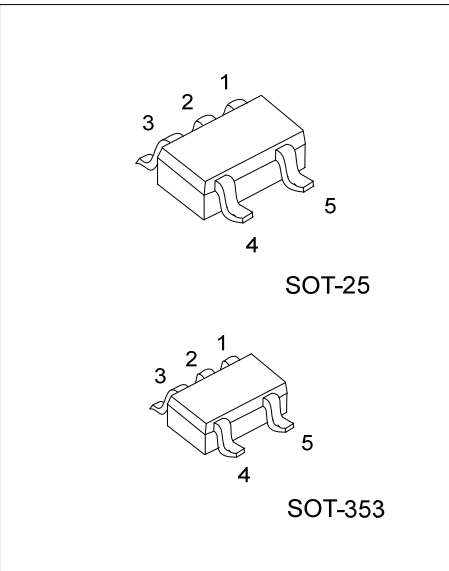

■ PIN CONFIGURATION

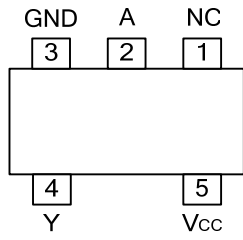

■ FUNCTION TABLE (each gate)

INPUT	OUTPUT
A	Y
L	L
H	H

■ LOGIC DIAGRAM (positive logic)



■ ABSOLUTE MAXIMUM RATING (unless otherwise specified)(Note 1)

PARAMETER	SYMBOL	RATINGS	UNIT
Supply Voltage	V_{CC}	-0.5~6.5	V
Input Voltage	V_{IN}	-0.5~6.5	V
Output Voltage(active mode)	V_{OUT}	-0.5~ $V_{CC}+0.5$	V
Output Voltage(power-down mode)	V_{OUT}	-0.5~6.5	V
Input Clamp Current($V_{IN}<0$)	I_{IK}	-50	mA
Output Clamp Current($V_O<0$)	I_{OK}	-50	mA
Output Current	I_{OUT}	± 50	mA
V_{CC} or GND Current	I_{CC}	± 100	mA
Storage Temperature	T_{STG}	-65 ~ +150	$^{\circ}C$

Notes: 1. The input and output voltage ratings may be exceeded if the input and output current ratings are observed.
 2. Absolute maximum ratings are those values beyond which the device could be permanently damaged.
 Absolute maximum ratings are stress ratings only and functional device operation is not implied.

■ RECOMMENDED OPERATING COMDITIONS

PARAMETER	SYMBOL	CONDITIONS	MIN	TYP	MAX	UNIT
Supply Voltage	V_{CC}	Operating	1.65		5.5	V
		Data retention only				V
Input Voltage	V_{IN}		0		5.5	V
Output Voltage	V_{OUT}		0		V_{CC}	V
Operating Temperature	T_A		-40		85	$^{\circ}C$

■ STATIC CHARACTERISTICS

PARAMETER	SYMBOL	TEST CONDITIONS	MIN	TYP	MAX	UNIT
Positive-going Input Threshold Voltage	V_{T+}	$V_{CC}= 1.65V$	0.76		1.16	V
		$V_{CC}= 2.3V$	1.08		1.56	
		$V_{CC}= 3.0V$	1.48		1.92	
		$V_{CC}= 4.5V$	2.16		2.74	
		$V_{CC}= 5.5V$	2.61		3.33	
Negative-going Input Threshold Voltage	V_{T-}	$V_{CC}= 1.65V$	0.35		0.62	V
		$V_{CC}= 2.3V$	0.56		0.88	
		$V_{CC}= 3.0V$	0.84		1.2	
		$V_{CC}= 4.5V$	1.41		1.97	
		$V_{CC}= 5.5V$	1.87		2.4	
Hysteresis Voltage ($V_{T+}-V_{T-}$)	ΔV_T	$V_{CC}= 1.65V$	0.36		0.64	V
		$V_{CC}= 2.3V$	0.45		0.78	
		$V_{CC}= 3.0V$	0.51		0.87	
		$V_{CC}= 4.5V$	0.58		1.04	
		$V_{CC}= 5.5V$	0.69		1.11	
High-Level Output Voltage	V_{OH}	$V_{CC}= 1.65V\sim 4.5V, I_{OH}=-100\mu A$	$V_{CC}-0.1$			V
		$V_{CC}= 1.65V, I_{OH}=-4mA$	1.2			
		$V_{CC}= 2.3V, I_{OH}=-8mA$	1.9			
		$V_{CC}= 3.0V, I_{OH}=-16mA$	2.4			
		$V_{CC}= 3.0V, I_{OH}=-24mA$	2.3			
Low-Level Output Voltage	V_{OL}	$V_{CC}= 1.65V\sim 4.5V, I_{OL}=100\mu A$			0.1	V
		$V_{CC}= 1.65V, I_{OL}=4mA$			0.45	
		$V_{CC}= 2.3V, I_{OL}=8mA$			0.3	
		$V_{CC}= 3.0V, I_{OL}=16mA$			0.4	
		$V_{CC}= 3.0V, I_{OL}=24mA$			0.55	
		$V_{CC}= 4.5V, I_{OL}=32mA$			0.55	

■ STATIC CHARACTERISTICS(Cont.)

PARAMETER	SYMBOL	TEST CONDITIONS	MIN	TYP	MAX	UNIT
Input Leakage Current	$I_{I(LEAK)}$	$V_{CC} = 0 \sim 5.5V, V_{IN} = V_{CC}$ or GND			±5	μA
Power OFF Leakage Current	I_{OFF}	$V_{CC} = 0V, V_{IN}$ or $V_{CC} = 5.5V$			±10	μA
Quiescent Supply Current	I_Q	$V_{CC} = 1.65V \sim 5.5V, V_{IN} = V_{CC}$ or GND $I_{OUT} = 0$			10	μA
Additional Quiescent Supply Current	ΔI_Q	$V_{CC} = 3V \sim 5.5V$, One input at $V_{CC} - 0.6V$, other inputs at V_{CC} or GND			500	μA
Input Capacitance	C_{IN}	$V_{CC} = 3.3V, V_{IN} = V_{CC}$ or GND		4.5		pF

■ DYNAMIC CHARACTERISTICS

PARAMETER	SYMBOL	$V_{CC}(V)$	$C_L = 15 \text{ pF}$		$C_L = 30 \text{ or } 50 \text{ pF}$		UNIT
			MIN	MAX	MIN	MAX	
Propagation delay from input (A or B) to output(Y)	t_{PLH}/t_{PHL}	1.8 ± 0.15	2.8	9.9	3.8	11	ns
		2.5 ± 0.2	1.6	5.5	2	6.5	
		3.3 ± 0.3	1.5	4.6	1.8	5.5	
		5 ± 0.5	0.9	4.4	1.2	5	
Operating Characteristics							
PARAMETER	SYMBOL	TEST CONDITIONS	$V_{CC} = 1.8V$	$V_{CC} = 2.5V$	$V_{CC} = 3.3V$	$V_{CC} = 5V$	UNIT
Power Dissipation Capacitance	Cpd	f=10MHz	20	21	22	25	pF

■ TEST CIRCUIT AND WAVEFORMS

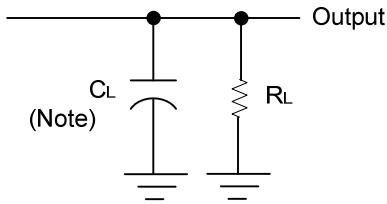

Note: C_L includes probe and jig capacitance.

V_{CC}	V_{IN}	t_R, t_F	V_M	C_L	R_L
$1.8V \pm 0.15V$	V_{CC}	$\leq 2ns$	$V_{CC}/2$	15pF	1M Ω
$2.5V \pm 0.2V$	V_{CC}	$\leq 2ns$	$V_{CC}/2$	15pF	1M Ω
$3.3V \pm 0.3V$	3V	$\leq 2.5ns$	1.5V	15pF	1M Ω
$5V \pm 0.5V$	V_{CC}	$\leq 2.5ns$	$V_{CC}/2$	15pF	1M Ω
$1.8V \pm 0.15V$	V_{CC}	$\leq 2ns$	$V_{CC}/2$	30pF	1K Ω
$2.5V \pm 0.2V$	V_{CC}	$\leq 2ns$	$V_{CC}/2$	30pF	500 Ω
$3.3V \pm 0.3V$	3V	$\leq 2.5ns$	1.5V	50pF	500 Ω
$5V \pm 0.5V$	V_{CC}	$\leq 2.5ns$	$V_{CC}/2$	50pF	500 Ω

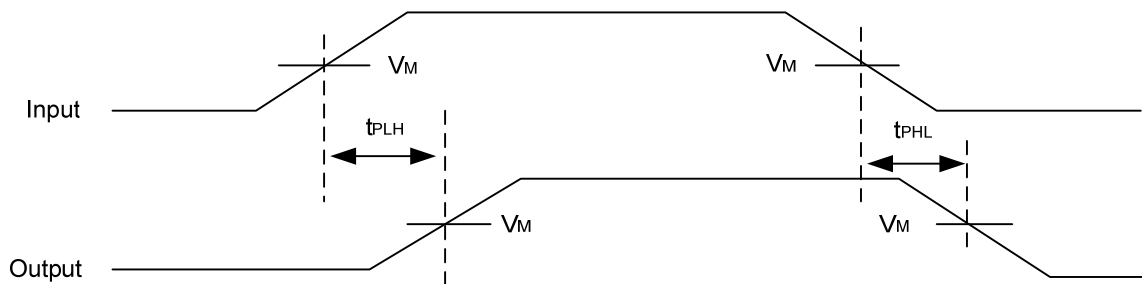

UTC assumes no responsibility for equipment failures that result from using products at values that exceed, even momentarily, rated values (such as maximum ratings, operating condition ranges, or other parameters) listed in products specifications of any and all UTC products described or contained herein. UTC products are not designed for use in life support appliances, devices or systems where malfunction of these products can be reasonably expected to result in personal injury. Reproduction in whole or in part is prohibited without the prior written consent of the copyright owner. The information presented in this document does not form part of any quotation or contract, is believed to be accurate and reliable and may be changed without notice.