



U74LVC245

CMOS IC

OCTAL BUS TRANSCEIVER WITH 3-STATE OUTPUTS

DESCRIPTION

The **U74LVC245** is designed for the communication between data buses asynchronously. While the direction-control(DIR) is high, data transmits from the A bus to the B bus. Data transmits from the B bus to the A bus if DIR is low. The output-enable(\overline{OE}) will isolate the device from the buses when high voltage is applied on it.

FEATURES

- * Operate From 1.65V to 3.6V
- * Input Accept Voltages to 5.5V
- * Partial-Power-Down Mode Operation

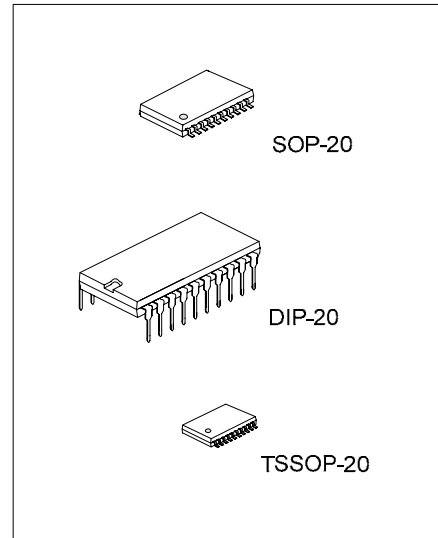

*Pb-free plating product number:
U74LVC245L

ORDERING INFORMATION

Ordering Number		Package	Packing
Normal	Lead Free Plating		
U74LVC245-D20-T	U74LVC245L-D20-T	DIP-20	Tube
U74LVC245-P20-R	U74LVC245L-P20-R	TSSOP-20	Tape Reel
U74LVC245-P20-T	U74LVC245L-P20-T	TSSOP-20	Tube
U74LVC245-S20-R	U74LVC245L-S20-R	SOP-20	Tape Reel
U74LVC245-S20-T	U74LVC245L-S20-T	SOP-20	Tube

<p>U74LVC245L-D20-T</p> <p>(1)Packing Type (2)Package Type (3)Lead Plating</p>	<p>(1) R: Tape Reel, T: Tube (2) D20: DIP-20, S20: SOP-20, P20: TSSOP-20 (3) L: Lead Free Plating, Blank: Pb/Sn</p>
--	---

■ PIN CONFIGURATION

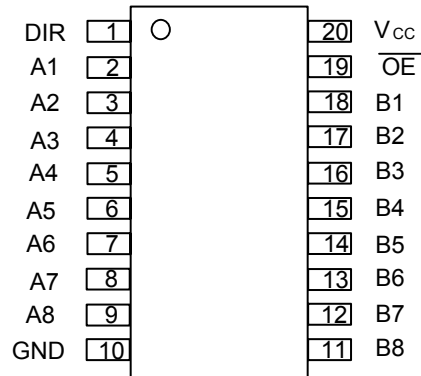

■ FUNCTION TABLE (each gate)

INPUT		FUNCTION
\overline{OE}	DIR	
H	x	Isolation
L	H	Transmit data from A bus to B bus
L	L	Transmit data from B bus to A bus

■ LOGIC DIAGRAM (positive logic)

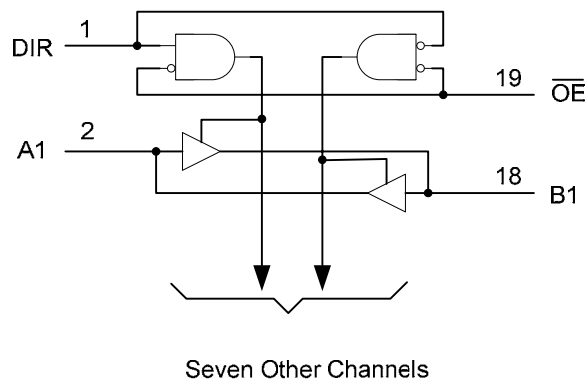

■ ABSOLUTE MAXIMUM RATINGS

PARAMETER	SYMBOL	RATINGS	UNIT
Supply Voltage	V_{CC}	-0.5~6.5	V
Input Voltage	V_{IN}	-0.5~ 6.5	V
Voltage Applied To Output In High-Impedance or Power-off State	V_{OUT}	-0.5~6.5	V
Voltage Applied to Output In High or Low State		-0.5~ $V_{CC}+0.5$	
Input Clamp Current	I_{IK}	-50	mA
Output Clamp Current	I_{OK}	-50	mA
Output Current	I_{OUT}	±50	mA
Vcc or GND Current	I_{CC}	±100	mA
Storage Temperature	T_{STG}	-65 ~ +150	

Note: 1. The input and output voltage ratings may be exceeded if the input and output current ratings are observed.
 2. Absolute maximum ratings are those values beyond which the device could be permanently damaged.
 Absolute maximum ratings are stress ratings only and functional device operation is not implied.

■ RECOMMENDED OPERATING CONDITIONS

PARAMETER	SYMBOL	TEST CONDITIONS	MIN	TYP	MAX	UNIT
Supply Voltage	V_{CC}	Operating	1.65		3.6	V
		Data retention only	1.5			
Input Voltage High-Level	V_{IH}	$V_{CC} = 1.65\text{ V to }1.95\text{ V}$	$0.65 \cdot V_{CC}$			V
		$V_{CC} = 2.3\text{ V to }2.7\text{ V}$	1.7			
		$V_{CC} = 2.7\text{ V to }3.6\text{ V}$	2			
Input Voltage Low-Level	V_{IL}	$V_{CC} = 1.65\text{ V to }1.95\text{ V}$			$0.35 \cdot V_{CC}$	V
		$V_{CC} = 2.3\text{ V to }2.7\text{ V}$			0.7	
		$V_{CC} = 2.7\text{ V to }3.6\text{ V}$			0.8	
Input Voltage	V_{IN}		0		5.5	V
Output Voltage	V_{OUT}		0		V_{CC}	V

■ ELECTRICAL CHARACTERISTICS

PARAMETER	SYMBOL	TEST CONDITIONS	MIN	TYP	MAX	UNIT
Output Voltage High-Level	V_{OH}	$V_{CC}=1.65\text{V to }3.6\text{V}, I_{OH} = -100\mu\text{A}$	$V_{CC}-0.2$			V
		$V_{CC}=1.65\text{V}, I_{OH} = -4\text{mA}$	1.29			
		$V_{CC}=2.3\text{V}, I_{OH} = -8\text{mA}$	1.9			
		$V_{CC}=2.7\text{V}, I_{OH} = -12\text{mA}$	2.2			
		$V_{CC}=3\text{V}, I_{OH} = -12\text{mA}$	2.4			
		$V_{CC}=3\text{V}, I_{OH} = -24\text{mA}$	2.3			
Output Voltage Low-Level	V_{OL}	$V_{CC}=1.65\text{V to }3.6\text{V}, I_{OL} = 100\mu\text{A}$			0.1	V
		$V_{CC}=1.65\text{V}, I_{OL} = 4\text{mA}$			0.24	
		$V_{CC}=2.3\text{V}, I_{OL} = 8\text{mA}$			0.3	
		$V_{CC}=2.7\text{V}, I_{OL} = 12\text{mA}$			0.4	
		$V_{CC}=3\text{V}, I_{OL} = 24\text{mA}$			0.55	
Input Leakage Current	$I_{I(LEAK)}$	$V_{CC}=3.6\text{V}, V_{IN} = 5.5\text{ V or GND}$			±1	uA
Power OFF Leakage Current	I_{OFF}	$V_{CC} = 0\text{V}, V_{IN} \text{ or } V_{CC} = 5.5\text{V}$			±1	uA
Input Leakage Current (For I/O Ports)	I_{OZ}	$V_{CC}=3.6\text{V}, V_{OUT} = 0 \sim 5.5\text{V}$			±1	uA
Quiescent Supply Current	I_Q	$V_{CC}=3.6\text{V}, V_{IN} = V_{CC} \text{ or GND } I_{OUT} = 0$			1	uA
		$V_{CC}=3.6\text{V}, 3.6\text{V}, V_{IN} = 5.5\text{V}, I_{OUT} = 0$			1	
Additional Quiescent Supply Current	ΔI_Q	$V_{CC}=2.7\text{V to }3.6\text{V}$, One input at V_{CC} -0.6V, Other inputs at V_{CC} or GND			500	uA
Input Capacitance	C_{IN}	$V_{CC}=3.3\text{V}, V_{IN} = V_{CC} \text{ or GND}$		4		pF

■ SWITCHING CHARACTERISTICS

PARAMETER	SYMBOL	TEST CONDITIONS	MIN	TYP	MAX	UNIT
From A to Y or From B to A	t_{PLH}/t_{PHL}	$V_{CC}=1.8V \pm 0.15V$	1	6	12.2	ns
		$V_{CC}=2.5V \pm 0.2V$	1	3.9	7.8	ns
		$V_{CC}=2.7V$	1	4.2	7.1	ns
		$V_{CC}=3.3V \pm 0.3V$	1.5	3.8	6.1	ns
From \overline{OE} to A or B	t_{PZL}/t_{PZH}	$V_{CC}=1.8V \pm 0.15V$	1	7	14.8	ns
		$V_{CC}=2.5V \pm 0.2V$	1	4.5	10	ns
		$V_{CC}=2.7V$	1	5.4	9.3	ns
		$V_{CC}=3.3V \pm 0.3V$	1.5	4.4	8.3	ns
From \overline{OE} A to A or B	t_{PLZ}/t_{PHZ}	$V_{CC}=1.8V \pm 0.15V$	1	7.8	16.5	ns
		$V_{CC}=2.5V \pm 0.2V$	1	4	9	ns
		$V_{CC}=2.7V$	1	4.4	8.3	ns
		$V_{CC}=3.3V \pm 0.3V$	1.7	4.1	7.3	ns

■ OPERATING CHARACTERISTICS

PARAMETER	SYMBOL	TEST CONDITIONS	MIN	TYP	MAX	UNIT
Power Dissipation Capacitance	Cpd	$\overline{OE}=0, f=10\text{MHZ}, V_{CC}=1.8V$		42		pF
		$\overline{OE}=0, f=10\text{MHZ}, V_{CC}=2.5V$		43		pF
		$\overline{OE}=0, f=10\text{MHZ}, V_{CC}=3.3V$		45		pF
		$\overline{OE}=1, f=10\text{MHZ}, V_{CC}=1.8V$		1		pF
		$\overline{OE}=1, f=10\text{MHZ}, V_{CC}=2.5V$		1		pF
		$\overline{OE}=1, f=10\text{MHZ}, V_{CC}=3.3V$		2		pF

TEST CIRCUIT AND WAVEFORMS

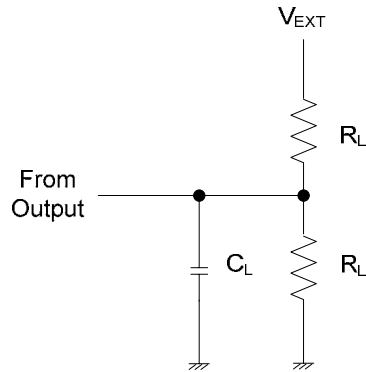

V _{CC}	V _{IN}	t _R /t _F	V _M	V	C _L	R _L	V _{EXT}		
							t _{PLH} /t _{PHL}	t _{PZH} /t _{PHZ}	t _{PZL} /t _{PLZ}
1.8V ±0.15V	V _{CC}	≤2ns	V _{CC} /2	0.15V	30 pF	1 kΩ	OPEN	GND	2*V _{CC}
2.5V ±0.2V	V _{CC}	≤2ns	V _{CC} /2	0.15V	30 pF	500Ω	OPEN	GND	2*V _{CC}
2.7V	2.7V	≤2.5ns	1.5V	0.3V	50 pF	500Ω	OPEN	GND	6V
3.3V ±0.3V	2.7V	≤2.5ns	1.5V	0.3V	50 pF	500Ω	OPEN	GND	6V

Fig-1 Load circuitry

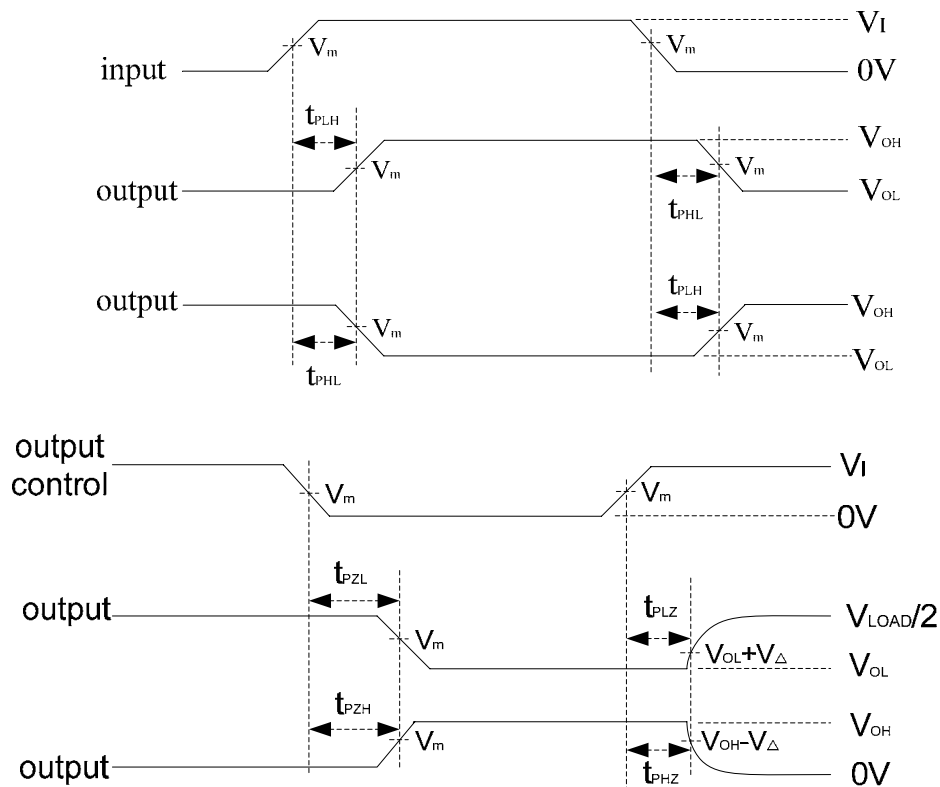

Fig-2 Propagation delay waves

UTC assumes no responsibility for equipment failures that result from using products at values that exceed, even momentarily, rated values (such as maximum ratings, operating condition ranges, or other parameters) listed in products specifications of any and all UTC products described or contained herein. UTC products are not designed for use in life support appliances, devices or systems where malfunction of these products can be reasonably expected to result in personal injury. Reproduction in whole or in part is prohibited without the prior written consent of the copyright owner. The information presented in this document does not form part of any quotation or contract, is believed to be accurate and reliable and may be changed without notice.