



UM605A/B

LINEAR INTEGRATED CIRCUIT

OPERATIONAL AMPLIFIERS WITH 1.25V/2.5V SHUNT REGULATOR

DESCRIPTION

UTC **UM605A/B** that is designed to include 2 op amp and one shunt regulator for battery charger and AC adapter application.

FEATURES

- * Small SOT-25 package
- * Internal accurate 1.25V/2.5V V_{REF}
- * Reduced external components

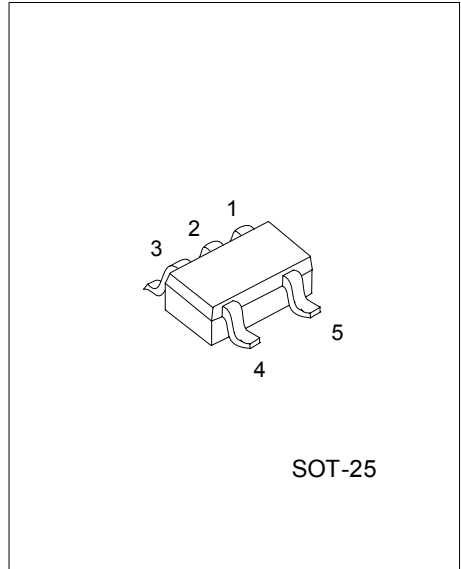

*Pb-free plating product number:
UM605AL/UM605BL

ORDERING INFORMATION

Ordering Number		Package	Packing
Normal	Lead Free Plating		
UM605A-AF5-R	UM605AL-AF5-R	SOT-25	Tape Reel
UM605B-AF5-R	UM605BL-AF5-R	SOT-25	Tape Reel

<p>UM605AL-AF5-R</p>	<p>(1)Packing Type (2)Package Type (3)Lead Plating</p>	<p>(1) R: Tape Reel (2) AF5: SOT-25 (3) L: Lead Free Plating, Blank: Pb/Sn</p>
----------------------	--	--

■ MARKING AND PIN DESCRIPTION

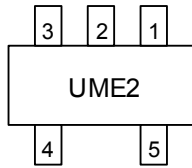

PIN NO.	PIN NAME	FUNCTION	INTERNAL CIRCUIT DIAGRAM
1	OUT	Output Pin	
2	GND	Ground	
3	IN _A	Input Pin	
4	IN _B		
5	V _{CC}	Supply Voltage	

■ BLOCK DIAGRAM

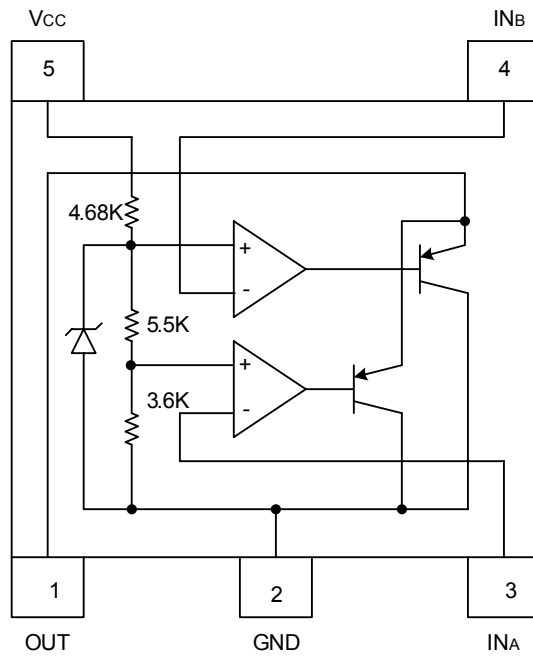

■ ABSOLUTE MAXIMUM RATINGS (Ta = 25)

PARAMETER	SYMBOL	RATINGS	UNIT
Supply Voltage	V _{CC}	-0.3 ~ +20	V
Recommended Operating Voltage	V _{OPR}	+4 ~ +20	V
Power Dissipation	P _D	250	mW
Operating Temperature	T _{OPR}	-25 ~ +85	
Storage Temperature	T _{STG}	-40 ~ +125	

Note: Absolute maximum ratings are those values beyond which the device could be permanently damaged. Absolute maximum ratings are stress ratings only and functional device operation is not implied.

■ ELECTRICAL CHARACTERISTICS (V_{CC}=5V, Ta=25 , unless otherwise specified.)

FOR UM605A

PARAMETER	SYMBOL	TEST CONDITIONS	MIN	TYP	MAX	UNIT
Current Consumption	I _{CC}	IN _A =0V, IN _B =0V, R _L =∞		2.4	3.4	mA
A AMPLIFIER						
Output Inverting Voltage	V _A	IN _A =0V, R _L =4.3k	1.225	1.25	1.275	V
Output Sink Current	I _{O(SINK A)}	IN _B =2.7V, IN _A =0V, V _{OUT} =1.5V	5			mA
Input Bias Current	I _{I(BIAS A)}	IN _A =0V, R _L =4.3k		50	140	nA
PSRR	PSRR(A)	IN _A =0V, R _L =4.3k	50			dB
B AMPLIFIER						
Output Inverting Voltage	V _B	IN _B =0V, R _L =4.3k	152		160	mV
Output Sink Current	I _{O(SINK B)}	IN _B =0V, IN _A =0.17V, V _{OUT} =1.5V	5			mA
Input Bias Current	I _{I(BIAS B)}	IN _B =0V, R _L =4.3k		50	140	nA
PSRR	PSRR(B)	IN _B =0V, R _L =4.3k	65			dB

FOR UM605B

PARAMETER	SYMBOL	TEST CONDITIONS	MIN	TYP	MAX	UNIT
Current Consumption	I _{CC}	IN _A =0V, IN _B =0V, R _L =∞		1.2	1.7	mA
A AMPLIFIER						
Output Inverting Voltage	V _A	IN _A =0V, R _L =4.3k	2.45	2.50	2.55	V
Output Sink Current	I _{O(SINK A)}	IN _B =2.7V, IN _A =0V, V _{OUT} =1.5V	5			mA
Input Bias Current	I _{I(BIAS A)}	IN _A =0V, R _L =4.3k		50	140	nA
PSRR	PSRR(A)	IN _A =0V, R _L =4.3k	62			dB
B AMPLIFIER						
Output Inverting Voltage	V _B	IN _B =0V, R _L =4.3k	152		160	mV
Output Sink Current	I _{O(SINK B)}	IN _B =0V, IN _A =0.17V, V _{OUT} =1.5V	5			mA
Input Bias Current	I _{I(BIAS B)}	IN _B =0V, R _L =4.3k		50	140	nA
PSRR	PSRR(B)	IN _B =0V, R _L =4.3k	65			dB

