



UP1856

PNP SILICON TRANSISTOR

HIGH CURRENT TRANSISTOR

■ FEATURES

- * High current switching
- * Low $V_{CE(SAT)}$
- * High h_{FE}

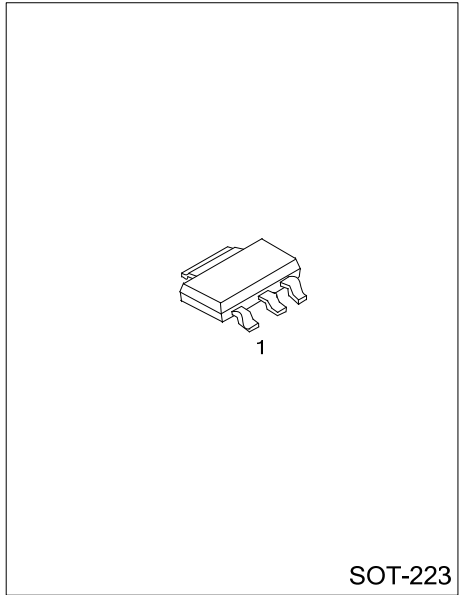

■ ORDERING INFORMATION

Ordering Number		Package	Pin Assignment			Packing
Lead Free	Halogen Free		1	2	3	
UP1856L-AA3-R	UP1856G-AA3-R	SOT-223	B	C	E	Tape Reel

<p>UP1856L-AA3-R</p> <p>(1)Packing Type (2)Package Type (3)Lead Plating</p>	<p>(1) R: Tape Reel (2) AA3:SOT-223 (3) G: Halogen Free, L: Lead Free</p>
---	---

■ ABSOLUTE MAXIMUM RATING

PARAMETER	SYMBOL	RATINGS	UNIT
Collector-Base Voltage	V_{CBO}	-220	V
Collector-Emitter Voltage	V_{CEO}	-200	V
Emitter-Base Voltage	V_{EBO}	-6	V
Peak Pulse Current	$I_{C(PEAK)}$	-5	A
Continuous Collector Current	I_C	-2	A
Power Dissipation at $T_a=25^\circ\text{C}$	P_D	1	W
Junction Temperature	T_J	+150	$^\circ\text{C}$
Storage Temperature	T_{STG}	-40 ~ +150	$^\circ\text{C}$

Note Absolute maximum ratings are those values beyond which the device could be permanently damaged. Absolute maximum ratings are stress ratings only and functional device operation is not implied.

■ ELECTRICAL CHARACTERISTICS ($T_a = 25^\circ\text{C}$ unless otherwise specified)

PARAMETER	SYMBOL	TEST CONDITIONS	MIN	TYP	MAX	UNIT
Collector-Emitter Breakdown Voltage	BV_{CEO}	$I_C = -10\text{mA}$, $I_B = 0$ (Note)	-200	-240		V
Collector-Base Breakdown Voltage	BV_{CBO}	$I_C = -0.1\text{mA}$, $I_E = 0$	-220	-300		V
Emitter-Base Breakdown Voltage	BV_{EBO}	$I_E = -0.1\text{mA}$, $I_C = 0$	-6	-8		V
Collector-Emitter Saturation Voltage (Note)	$V_{CE(SAT)}$	$I_C = -100\text{mA}$, $I_B = -10\text{mA}$		-30	-50	mV
		$I_C = -1\text{A}$, $I_B = -100\text{mA}$		-120	-165	mV
		$I_C = -2\text{A}$, $I_B = -400\text{mA}$		-168	-275	mV
Base-Emitter Saturation Voltage	$V_{BE(SAT)}$	$I_C = -2\text{A}$, $I_B = -400\text{mA}$		-970	-1110	mV
Base-Emitter Turn-On Voltage	$V_{BE(ON)}$	$V_{CE} = -5\text{V}$, $I_C = -2\text{A}$ (Note)		-810	-950	mV
Collector Cut-Off Current	I_{CBO}	$V_{CB} = -200\text{V}$, $I_E = 0$			-50	nA
Emitter Cut-Off Current	I_{EBO}	$V_{EB} = -6\text{V}$, $I_C = 0$			-10	nA
DC Current Gain (Note)	h_{FE1}	$V_{CE} = -5\text{V}$, $I_C = -10\text{mA}$	100	200	300	
	h_{FE2}	$V_{CE} = -5\text{V}$, $I_C = -1\text{A}$	100	200		
	h_{FE3}	$V_{CE} = -5\text{V}$, $I_C = -2\text{A}$	50	150		
	h_{FE4}	$V_{CE} = -5\text{V}$, $I_C = -5\text{A}$		10		
Transition Frequency	f_T	$V_{CE} = -10\text{V}$, $I_C = -100\text{mA}$, $f = 50\text{MHz}$		110		MHz
Output Capacitance	C_{ob}	$V_{CB} = -20\text{V}$, $f = 1\text{MHz}$		32		pF
Turn-on Time	t_{ON}	$I_C = -1\text{A}$, $I_{B1} = -100\text{mA}$		67		ns
Turn-off Time	t_{OFF}	$I_{B2} = 100\text{mA}$, $V_{CC} = -50\text{V}$		1140		ns

Note: Pulsed test: duty cycle $\leq 2\%$, $t_P = 300\mu\text{s}$.

TYPICAL CHARACTERISTICS

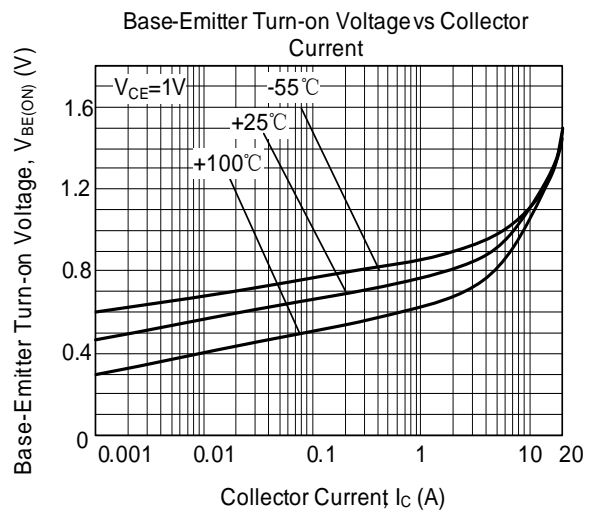
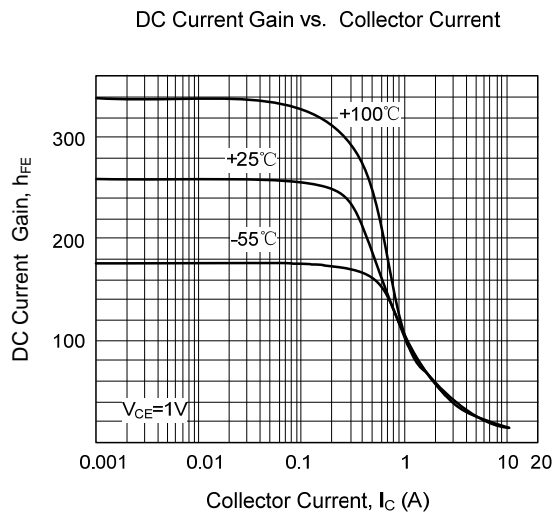
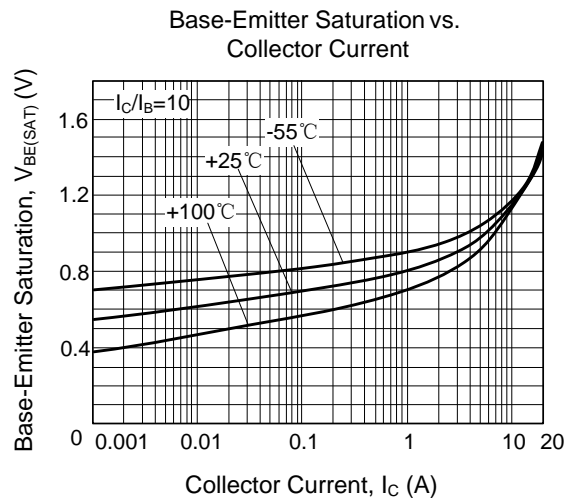
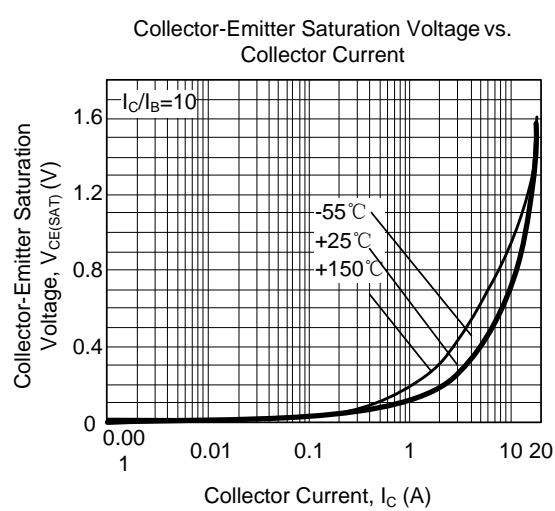

UTC assumes no responsibility for equipment failures that result from using products at values that exceed, even momentarily, rated values (such as maximum ratings, operating condition ranges, or other parameters) listed in products specifications of any and all UTC products described or contained herein. UTC products are not designed for use in life support appliances, devices or systems where malfunction of these products can be reasonably expected to result in personal injury. Reproduction in whole or in part is prohibited without the prior written consent of the copyright owner. The information presented in this document does not form part of any quotation or contract, is believed to be accurate and reliable and may be changed without notice.