



DUAL USB HIGH-SIDE POWER SWITCH

DESCRIPTION

The UTC **US3076** is an integrated dual channel for USB high-side power switch. It particularly designed for self-powered and bus-powered Universal Serial Bus (USB) applications.

The $R_{DS(ON)}$ of the MOSFET switch is as low as 87mΩ. \overline{OC} which is open-drain output report over-current or over-temperature event, has deglitch timeout period typically 9ms.

The UTC **US3076** incorporates some protection circuits, such as current limiting circuit with foldback function, thermal shutdown circuit which is designed to prevent catastrophic switch failure due to increasing power dissipation when continuous heavy loads or short circuit occurs. A built-in charge pump is used to drive the N-channel MOSFET that is free of parasitic body diode to eliminate any reversed current flow across the switch when it is powered off.

The UTC **US3076** is applied in high-side power protection switch, USB power management, USB host and self-powered bubs, USB bus-powered hubs, hot plug-in power supplies, and battery-charger circuits.

FEATURES

- * Operating on the Range of 2.7V to 5.5V
- * High-Side MOSFET with 87mΩ $R_{DS(ON)}$
- * Quiescent Supply Current: 65μA
- * Available with 4 Versions of Current Limits with Foldback
- * Rise Time: 400μS (TYP)
- * UVLO (Under Voltage Lockout)
- * Shutdown Supply Current: 1μA (MAX)
- * Reverse Current is not Generated when in Power Off State
- * Deglitched Open-Drain Over-Current Flag Output (\overline{OC})

ORDERING INFORMATION

Ordering Number	Package	Packing
US3076XXG-S08-R	SOP-8	Tape Reel

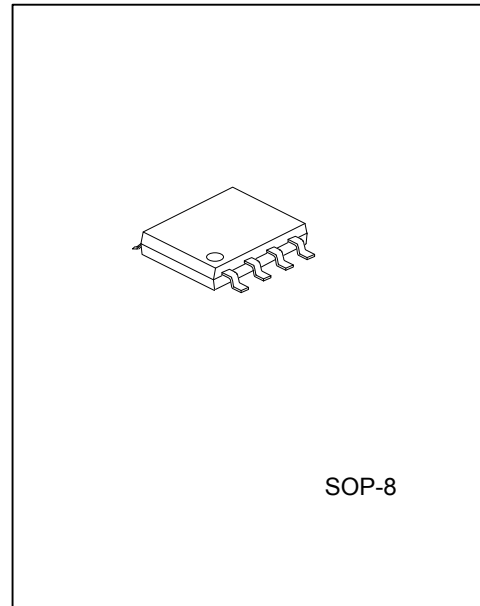

<p>US3076XXG-S08-R</p> <ul style="list-style-type: none"> (1) Packing Type (2) Package Type (3) Halogen Free (4) Logic Level Enable Pin (5) Current Limit 	<ul style="list-style-type: none"> (1) R: Tape Reel (2) S08: SOP-8 (3) G: Halogen Free (4) 1: Active High 2: Active Low (5) A: 2A, B:1.5A, C: 1A, D:0.75A
--	--

■ PIN CONFIGURATION

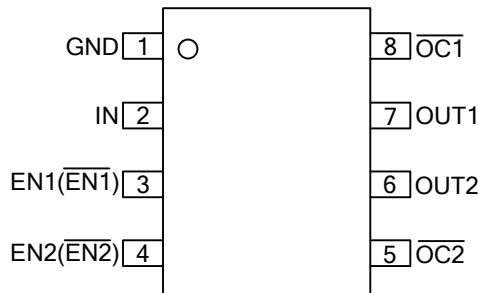

■ PIN DESCRIPTION

PIN NO.	PIN NAME	DESCRIPTION
1	GND	Ground
2	IN	Input Supply: Output MOSFET Drain, which also supplies IC's internal circuitry. Connect to positive supply.
3	EN1($\overline{\text{EN1}}$)	Enable: Logic level enable input of switch 1. Make sure EN pin never floating.
4	EN2($\overline{\text{EN2}}$)	Enable: Logic level enable input of switch 2. Make sure EN pin never floating.
5	$\overline{\text{OC2}}$	Over-Current: Open-Drain OC output of switch 2.
6	OUT2	Switch Output: Output MOSFET Source of switch 2. Typically connect to switched side of load.
7	OUT1	Switch Output: Output MOSFET Source of switch 1. Typically connect to switched side of load.
8	$\overline{\text{OC1}}$	Over-Current: Open-Drain OC output of switch 1.

■ BLOCK DIAGRAM

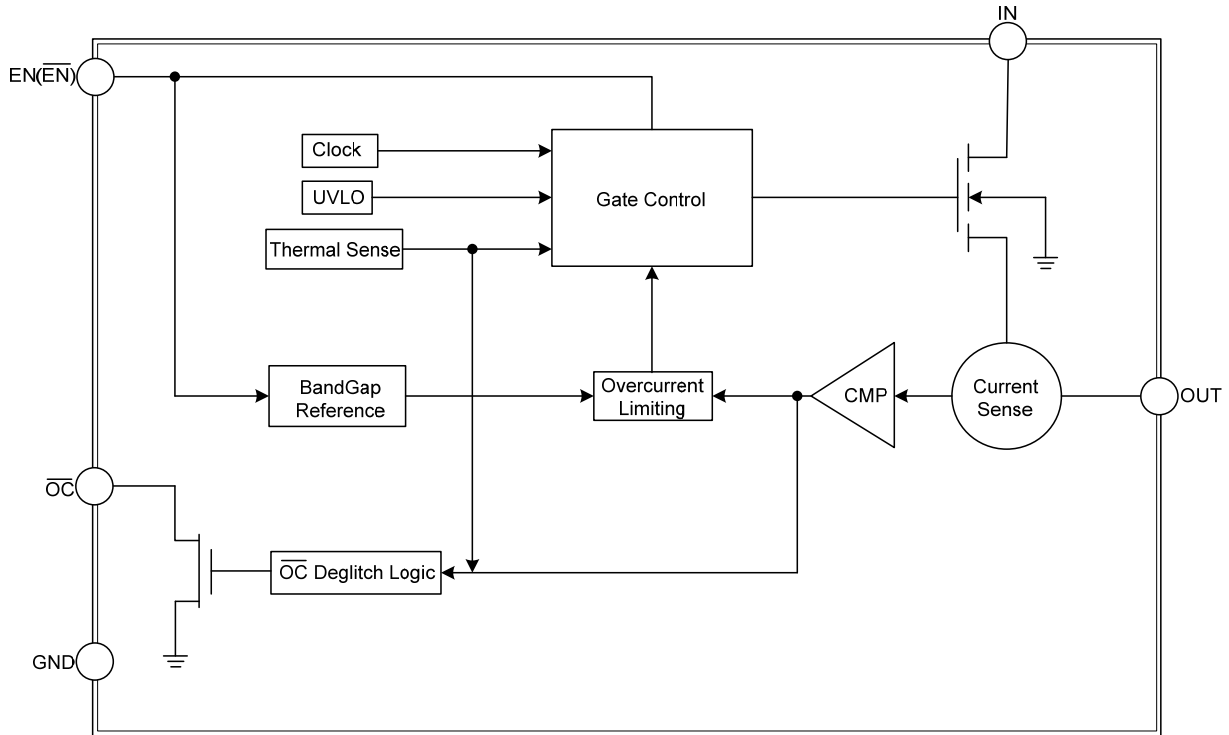

■ ABSOLUTE MAXIMUM RATING

PARAMETER	SYMBOL	RATINGS	UNIT
Supply Voltage	V_{IN}	6	V
Output Voltage	V_{OUT}	6	V
Output Current	I_{OUT}	Internally Limited	A
Enable Input	V_{EN}	-0.3 ~ 6	V
Storage Temperature	T_{STG}	-65~ +150	°C

Note: 1. Absolute maximum ratings are those values beyond which the device could be permanently damaged. Absolute maximum ratings are stress ratings only and functional device operation is not implied.

■ OPERATING RATINGS

PARAMETER	SYMBOL	RATINGS	UNIT
Supply Voltage	V_{IN}	+3 ~ +5.5	V
Ambient Operating Temperature	T_{OPR}	-40~ +85	°C

■ ELECTRICAL CHARACTERISTICS

($V_{IN}=5V$, $C_{IN}=1\mu F$, $C_{OUT}=1\mu F$, $R_L=10\Omega$, $T_A=25^\circ C$, Unless otherwise specified)

PARAMETER	SYMBOL	TEST CONDITIONS	MIN	TYP	MAX	UNIT	
Input Voltage	V_{IN}		2.7		5.5	V	
Output MOS $R_{DS(ON)}$		US3076A, $I_{OUT} = 1.5A$		87	103	mΩ	
		US3076B, $I_{OUT} = 1.0A$					
		US3076C, $I_{OUT} = 0.5A$					
		US3076D, $I_{OUT} = 0.3A$					
Supply Current	I_{IN}			90	150	μA	
Output Turn-on Rising Time		$R_L=10\Omega$, 90% Settling		400		μs	
Current Limit Threshold	$I_{THD(LIMIT)}$	$V_{OUT}=4V$	US3076A	1.5	2	2.8	A
			US3076B	1.1	1.5	2.1	A
			US3076C	0.7	1	1.4	A
			US3076D	0.5	0.75	1.7	A
Short-circuit Current	I_{SC}	$V_{OUT}=0V$, $2.7V < V_{IN} < 5.5V$	US3076A	0.2	1.3	1.9	A
			US3076B	0.2	1	1.4	A
			US3076C	0.2	0.67	1	A
			US3076D	0.2	0.5	0.7	A
EN Input Threshold			1.2	1.6	2	V	
Shutdown Supply Current	I_{SHDN}				1	μA	
Output Leakage Current	$I_{O(LEAK)}$	EN="0", $V_{OUT}=0V$			1	μA	
V_{IN} Under Voltage Lockout			2.1	2.3	2.65	V	
V_{IN} Under Voltage Hysteresis				200		mV	
Thermal Limit				135		°C	
Thermal Limit Hysteresis				20		°C	
\overline{OC} Deglitch		\overline{OC} assertion or deassertion	5	9	15	ms	
\overline{OC} Output Low Voltage		$I_{\overline{OC}} = 5mA, V_{IN} = 2.7V$			0.2	V	
\overline{OC} Off-State Current		$V_{\overline{OC}} = 5V$			1	μA	

■ TEST CIRCUIT

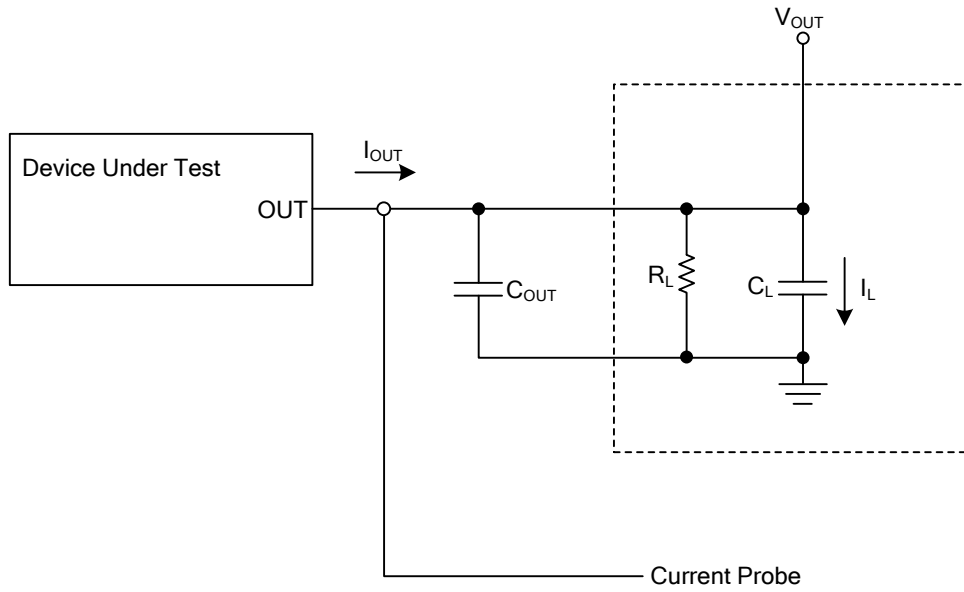

■ TIMING DIAGRAMS

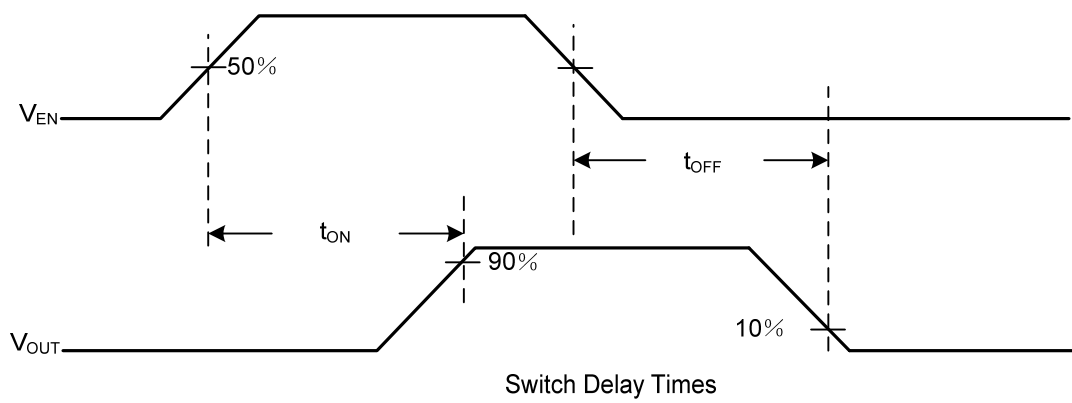
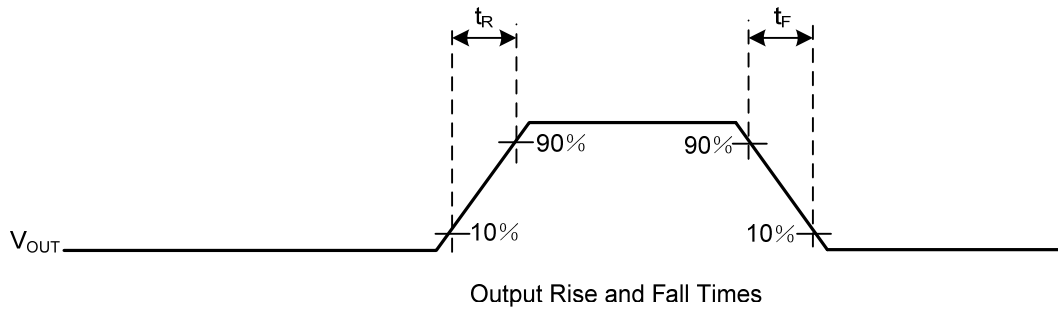

■ TYPICAL APPLICATION CIRCUIT

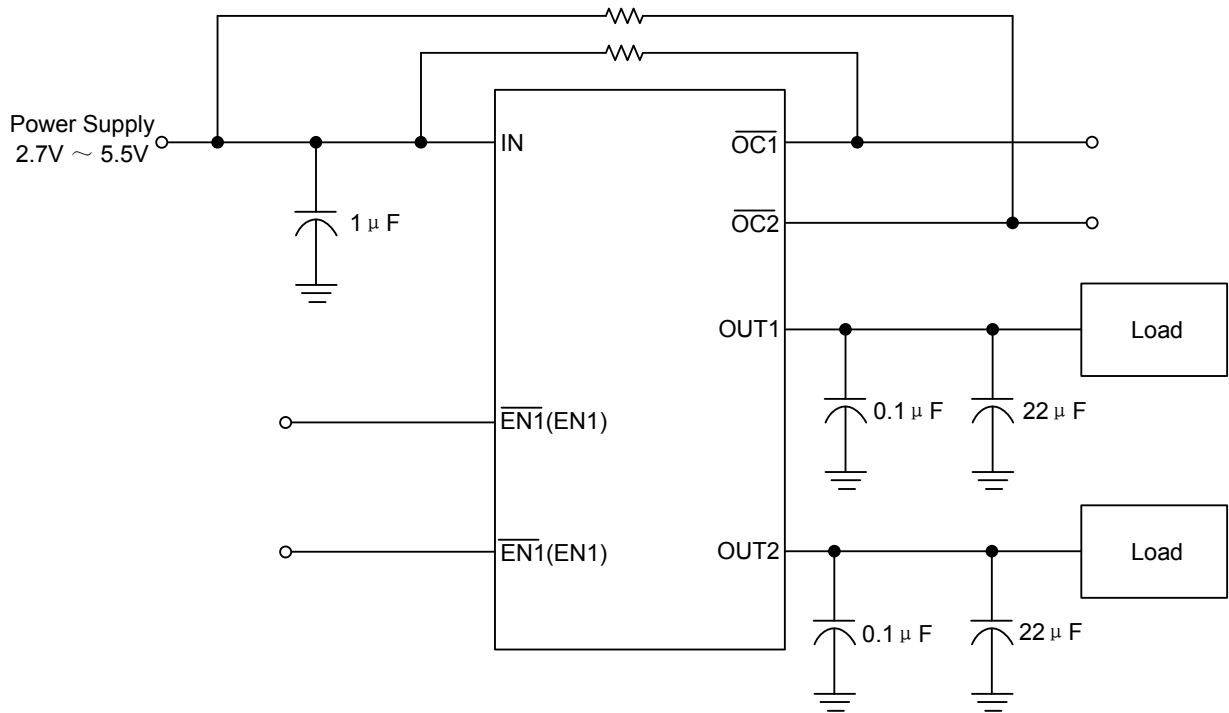

■ FUNCTIONAL DESCRIPTION

Input and Output

IN pin (Input) is the power supply connection to the logic circuitry and the drain of the output MOSFET. OUT pin (Output) is the source of the output MOSFET. Current flows through the switch from input to output toward the load in a typical application. Both OUT pins must be connected together to the load.

Thermal Shutdown

Thermal shutdown is designed to prevent this device from being damaged due to excessive power dissipation. It is used to turn off the output MOSFET when the if the temperature is higher than 135°C, 20°C of hysteresis prevents the switch turn on until the die temperature drops to 115°C. Thermal shutdown circuit functions only when the switch is enabled.

Under-Voltage Lockout

UVLO (Under Voltage Lockout) turns off the MOSFET switch once the input voltage falls below 2.3V (TYP.) and if the input voltage exceeds 2.5V (TYP.), the switch will be turned on. UVLO detection functions only when the switch is enabled.

Current Limiting

The current limit value is fixed internally, typically 2A, 1.5A, 1A, 0.75A for US3076A /US3076B/ US3076C/ US3076D respectively. There is foldback of current limit When V_{OUT} is less than 1.5V, there is foldback of current limit.

\overline{OC} Function

The \overline{OC} open-drain output is asserted (active low) when an over-current or over-temperature shutdown condition is encountered after a 9-ms deglitch timeout. The output remains asserted until the over current or over temperature condition is removed.

■ APPLICATION INFORMATION

Supply Filtering

To avoid supply transients, 1 μ F bypass capacitor is strongly recommended to located between IN to GND. Without a bypass capacitor, an output short may cause sufficient ringing on the input (from supply lead inductance) to damage internal control circuitry.

Input transients value must be not higher than the absolute maximum supply voltage ($V_{IN\ max} = 6V$) even for a short duration.

EN, the Enable Input

The enable pin, EN, must be driven logic high or logic low for a clearly defined input. The input is not allowed to float, or unpredictable operation may be occurs. EN should not be allowed to go negative with respect to GND.

UTC assumes no responsibility for equipment failures that result from using products at values that exceed, even momentarily, rated values (such as maximum ratings, operating condition ranges, or other parameters) listed in products specifications of any and all UTC products described or contained herein. UTC products are not designed for use in life support appliances, devices or systems where malfunction of these products can be reasonably expected to result in personal injury. Reproduction in whole or in part is prohibited without the prior written consent of the copyright owner. The information presented in this document does not form part of any quotation or contract, is believed to be accurate and reliable and may be changed without notice.