

產品尺寸圖 (DIMENSION)

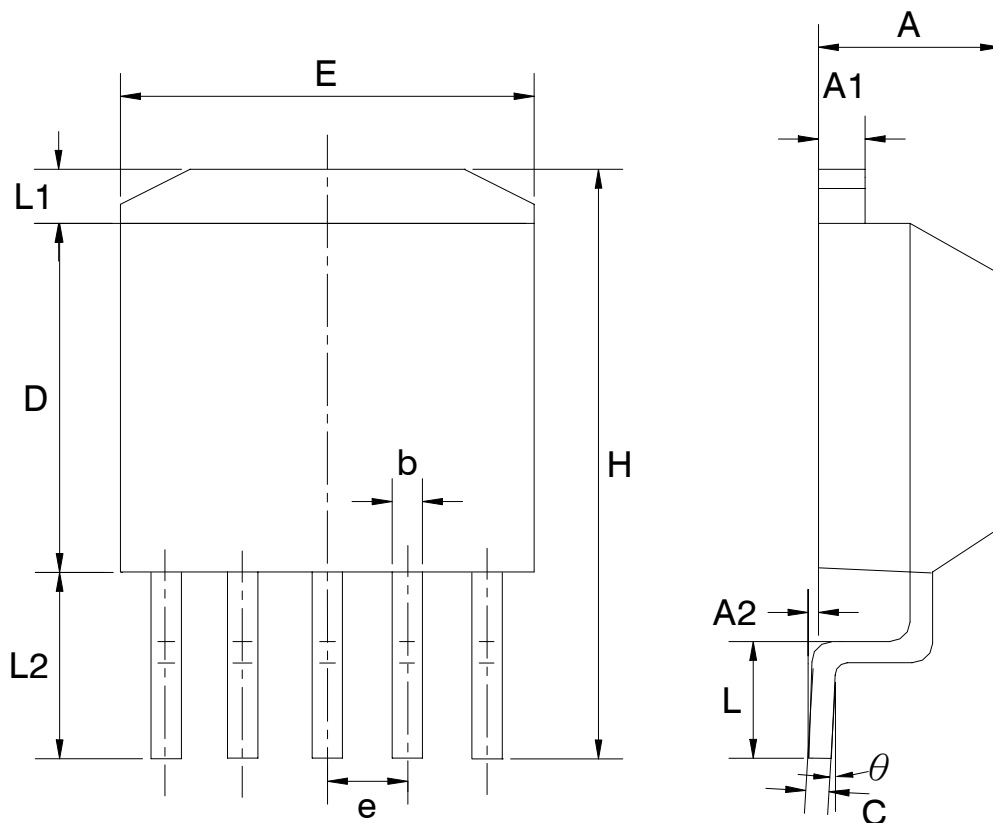

Symbol	Dimensions In Millimeters			Dimensions in Inches		
	Min	Nom	Max	Min	Nom	Max
A	4.06	-	4.83	0.160	-	0.190
A1	1.14	-	1.40	0.045	-	0.055
A2	0.00	-	0.30	0.000	-	0.012
b	0.51	-	0.99	0.020	-	0.039
C	0.31	-	0.74	0.012	-	0.029
D	8.20	-	9.65	0.322	-	0.380
E	9.65	-	10.54	0.380	-	0.415
e	1.70 BSC			0.067 BSC		
H	14.60	-	15.88	0.575	-	0.625
L1	-	-	1.76	-	-	0.069
L2	4.73	-	5.72	0.186	-	0.225
θ	0°	-	8°	0°	-	8°

Note : QC. Inspection Range : A,A1,A2,b,C,D,E,H

PACKAGE	TO-263-5	
DRAWING	DIM-TO263-5-0505-A	
SIGNATURE	製圖	莊立德
	審核	王啓任
	核准	許敏龍

UTC UNISONIC TECHNOLOGIES CO.,LTD.