

產品尺寸圖 (DIMENSION)

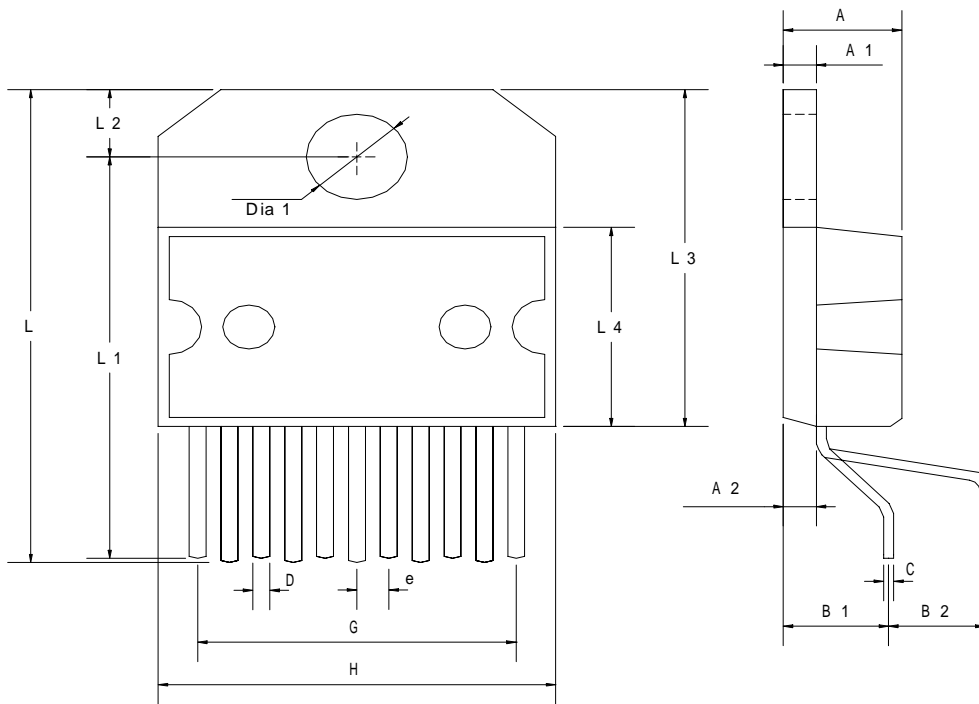

Symbol	Dimensions In Millimeters			Dimensions in Inches		
	Min	Nom	Max	Min	Nom	Max
A	4.40	-	5.00	0.173	-	0.197
A1	1.40	-	1.60	0.055	-	0.063
A2	2.45	-	2.65	0.096	-	0.104
B1	4.25	-	4.85	0.167	-	0.191
B2	4.73	-	5.43	0.186	-	0.214
C	0.49	-	0.55	0.019	-	0.022
D	0.88	-	0.95	0.035	-	0.037
e	1.45	-	1.95	0.057	-	0.077
G	16.75	-	17.25	0.659	-	0.679
H	19.60	-	21.60	0.772	-	0.850
L	24.55	-	25.40	0.967	-	1.000
L1	21.69	-	22.50	0.854	-	0.886
L2	2.66	-	2.90	0.105	-	0.114
L3	17.25	-	17.75	0.679	-	0.699
L4	10.30	-	10.90	0.406	-	0.429
Dia1	3.65	-	3.85	0.144	-	0.152

Note : QC. Inspection Range : A,C,D,H,L4

PACKAGE	HZIP-11A	
DRAWING NUMBER	DIM-HZIP11A-0508-A	
SIGNATURE	製圖	莊立德
	審核	王啓任
	核准	許敏龍